

DTF Shaking Powder Device Technical Manual Book

1.Function description

This equipment is suitable for the drying process of white ink painting process, this product is carefully developed by our nearly 20 years of experience in the development of similar products combined with the characteristics of the digital printing industry, with energy-saving environmental protection, efficient and reliable, beautiful, easy to operate and other remarkable features, the series of products on the market for many years by the majority of users of friends unanimously recognized.

Your satisfaction, my pursuit! We are committed to the purpose of dedicated customer service to make every detail of products and services, with a view to Your Business Development to provide strong support.

2.Device style



3.Main characteristic parameter

Name of equipment	DTF Shaking Powder Device
Type of equipment	XF-C600
Equipment operation	White ink hot painting powder drying process
Equipment size	W1250mm * D980mm * H1050mm
Film gauge	600mm/300mm
Rated power	2.8KW
Average energy consumption on site	1KWH/H(10 hours non-stop working status of the measured data)
Temperature range	0--100°C
Boot-up time	5 minutes
Equipment Power	Single phase three wire system

CONTROL PANEL BUTTON INSTRUCTIONS:



1. Powder-spraying speed, its working mechanism is to control the powder-spraying motor speed by adjusting the motor's working voltage, and the powder-spraying motor drives the brush to the powder-spraying speed, so as to achieve the different effects required by the product;
2. Shake powder speed: the adjustable Rotary Torque by adjusting the working voltage of the motor to control the shake powder motor speed, shake powder motor through the connecting rod to drive shake powder film, the appropriate shake powder speed can be applied to different product requirements of different effects;
3. Curing temperature: the powder Shaker can adjust the working temperature of the drying area by this function. Because of different working environment and product medium, there are different requirements for curing temperature, when the actual use needs to be adjusted according to the product and material characteristics;
4. Power Switch: This is the power control switch of the equipment;
5. Powder powder: This is the powder motor function control switch;
6. Dusting powder: This is the function of dusting powder motor control switch
7. Curing: This is the control of heating work heating Functional Control Switch
8. Cooling: Control of the discharge Port Three Cooling Fan working state; 9. PRE-HEATING: control the preheating state of the heating table plate at the inlet;

4. STEP BY STEP:

1. Choose the proper power supply according to the regulation, connect the power supply of the equipment according to the standard, and adjust the level of the fixed equipment;
2. Debug the printer and pass the film through the printer and duster ;
3. The powder box with hot powder, pay attention not to add too full powder, to just flooded brush for the appropriate, the normal dusting speed is 2 hours plus a powder;
4. Turn on the dusting switch, and adjust the dusting speed spin to the right amount of powder can be;
5. Turn on the dusting switch, and adjust the dusting speed to the right speed;
6. Turn on the curing switch, and adjust the curing temperature to 100 degrees, the recommended curing temperature adjustment range of 90-130 degrees (different workplace parameters slightly different) ;
7. The printer can enter the working state when the curing temperature of the dusting machine is constant. The dusting machine is an automatic induction receiving working mode.

5. Points to note:

1. The power supply voltage should be in a reasonable range and the power supply should be connected to the ground to ensure good grounding equipment to ensure the normal work of equipment and Personal Safety of operators;
2. The fluctuation range of the power supply voltage should be less than $\pm 5\%$. Too Low voltage will affect the working efficiency of the equipment. Too High Voltage will shorten the service life of the key components of the equipment;
3. If not used for a long time (more than 3 days) should unplug the power plug;
4. The product must be installed horizontally, to ensure that the work of the equipment do not shake, adjust the position, the brake casters fixed;
5. The installation of the position must be well ventilated, because the duster will produce smoke and a lot of water vapor when it is working, the duster exhaust port is recommended to install smoke purifier, the room is recommended to install exhaust fan; this is very important: hot powder is sensitive to water vapor and temperature, a good working environment can reduce the failure rate of equipment, improve product stability;
6. The production of product quality needs the appropriate temperature and appropriate working speed, a good working environment can greatly improve the service life of equipment and produce more stable products.

6. General troubleshooting:

Phenomenon	Why	Method of elimination
The whole machine does not work	1. The power supply is not connected; 2. The circuit is not in good contact	1. Check and turn on the power; 2. Check the circuit and return it to normal
The powder does not fall when dusted	1. The brush is stuck; 2. The motor shaft is loose and not locked	1. Clean the powder in the powder box and solve the problem of ventilation in the place of use; 2. Lock the loose screw tightly
The paper receiver is not working properly	1. Too much powder causes it to pile up and block the sensor's line of sight; 2. Sensor looseness or abnormal position; 3. Circuit failure	1. Clean up the excess hot powder; 2. Re-adjust the position of the sensor and fixed; 3. Repair the circuit

Precision adjustment

The first step, Vertical check

Click in order Adjust→Head Instance→Vertical check→Print Adjust

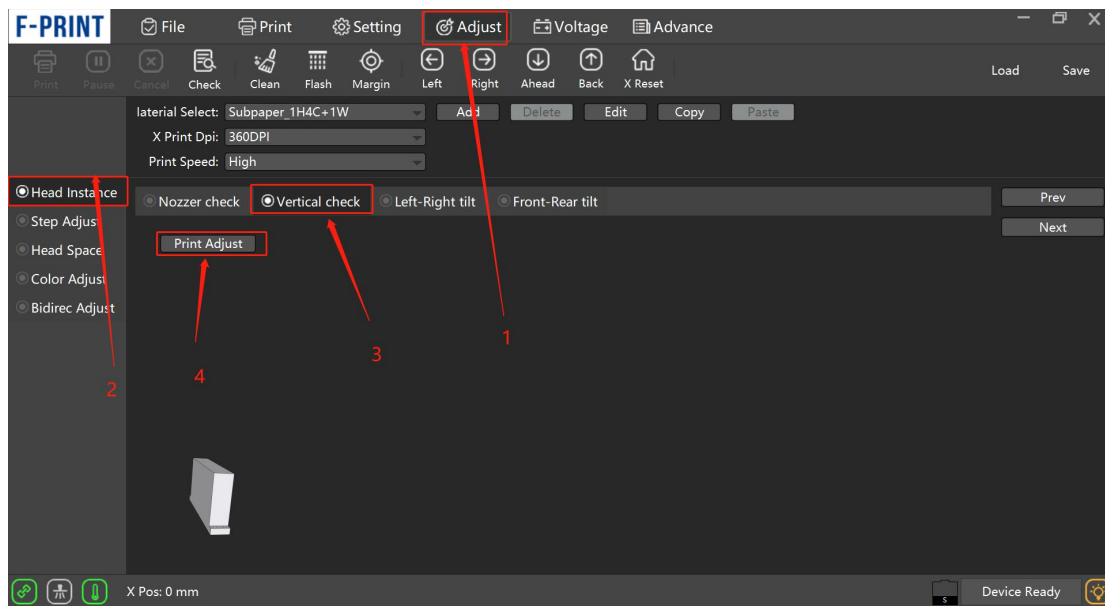

Because this step is more important, please send the printed result to the technician and make adjustments with the assistance of the technician

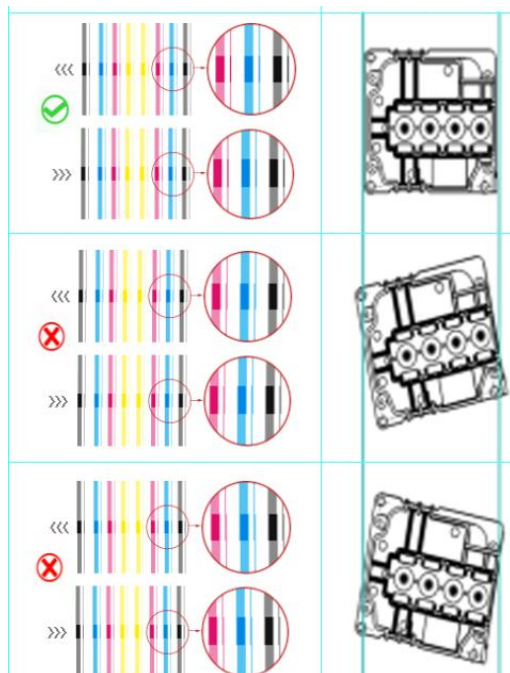

The second step, step adjust

Click Step Adjust → Print Adjust

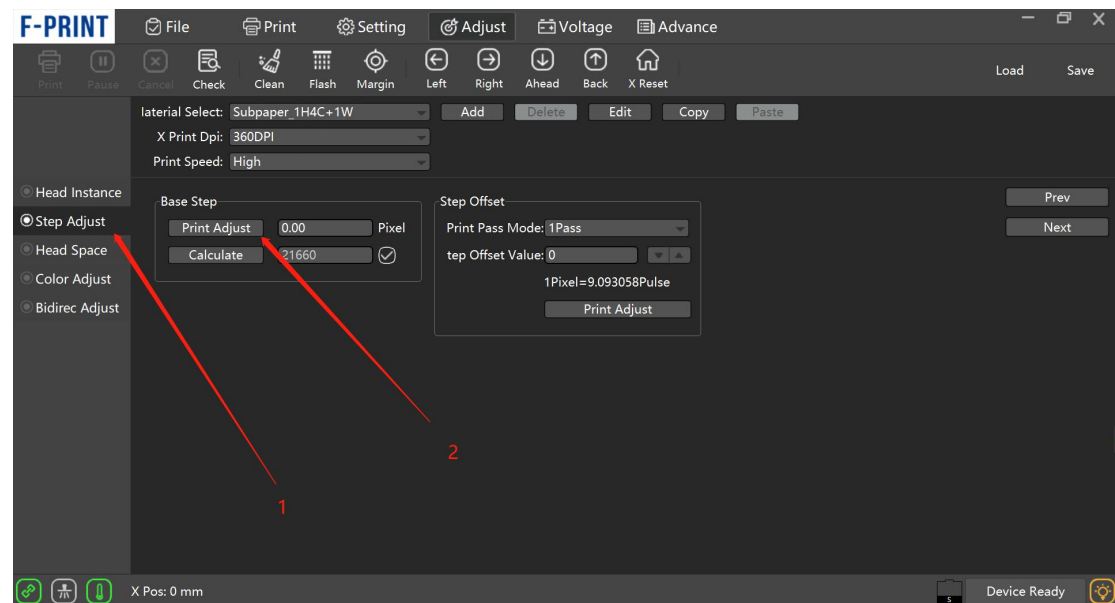

Check the print result, find the same pattern as shown in Figure-3 below, where the lines on both sides are parallel, check the specific number according to your actual printing situation

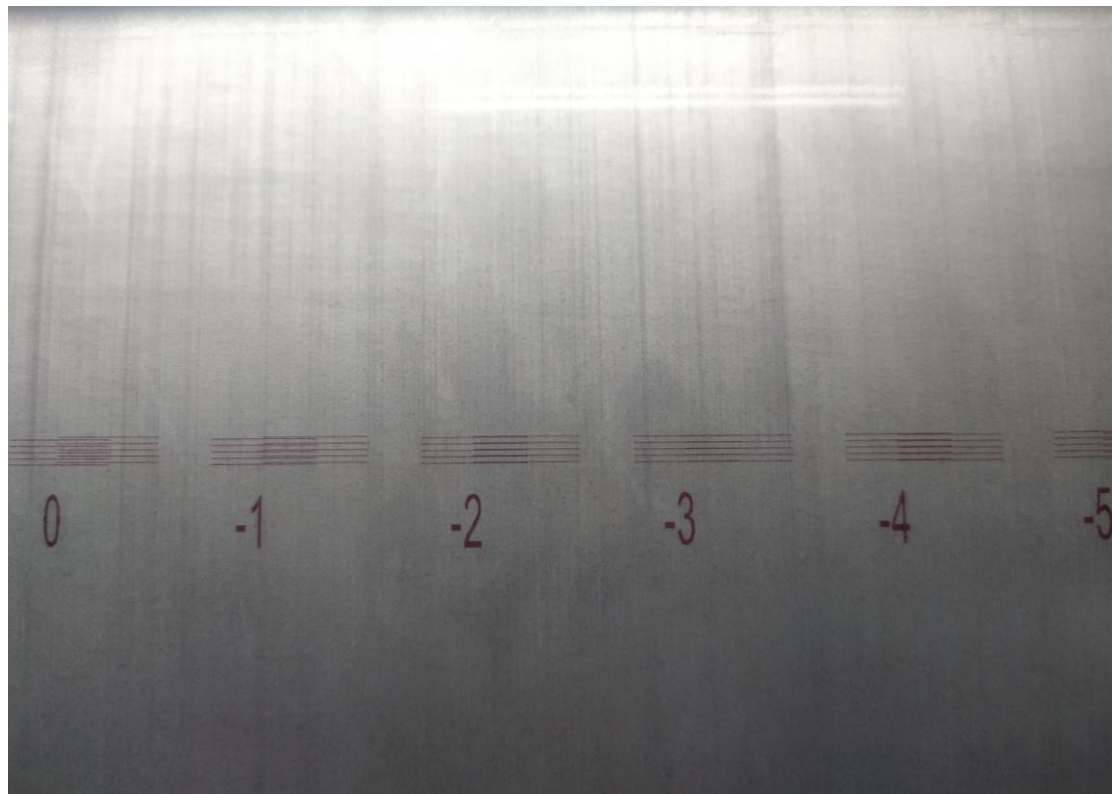

Then fill this number into the area indicated in the figure below, click calculate, then click save
【ps: The number here is to fill in 0.5 according to your own estimation】

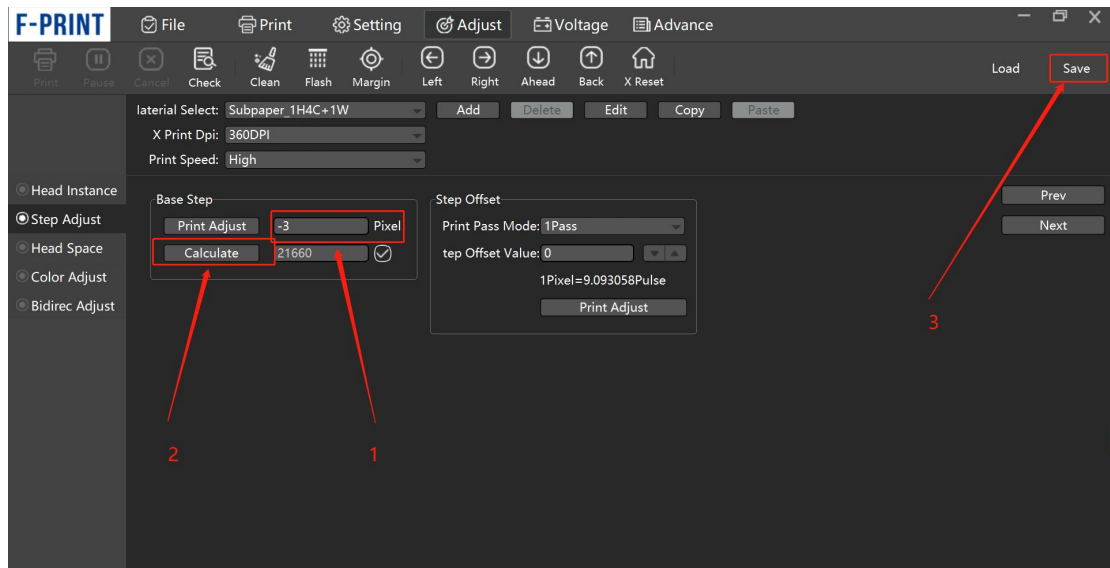

Print again, Repeat calibration until the pattern of number 0 is parallel

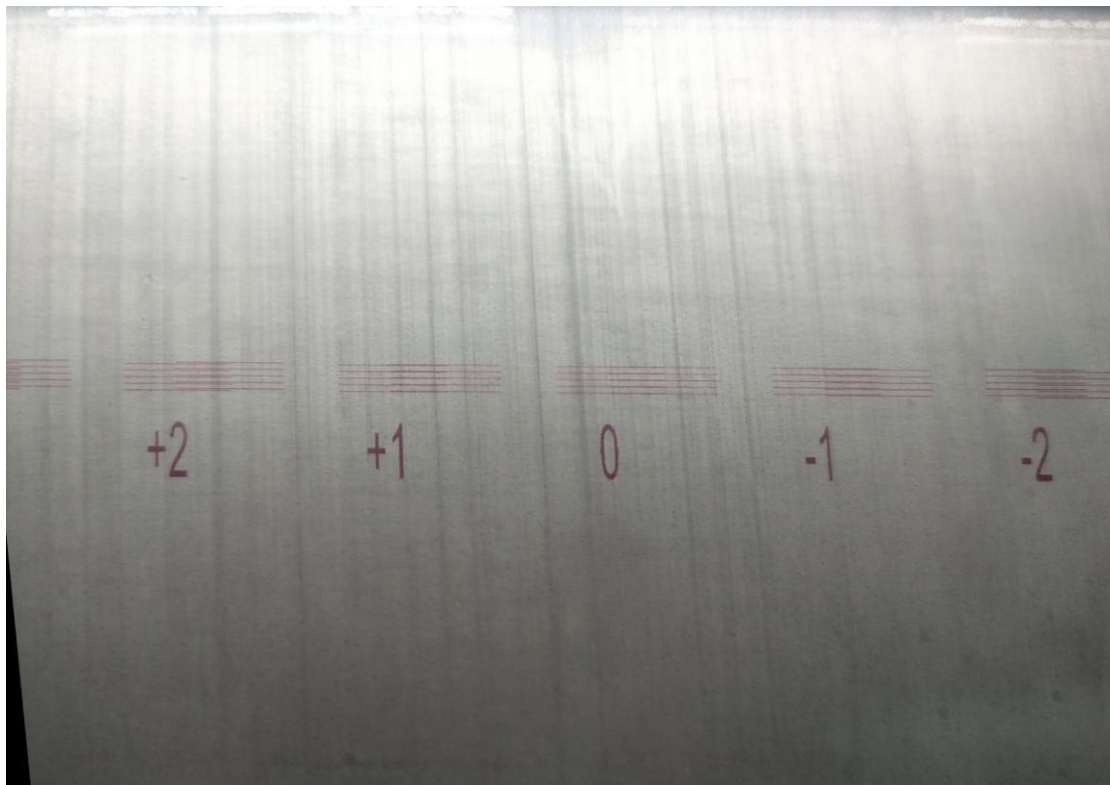

The third step, head space

Horizontal distance

Horizontal distance is divided into two directions, left and right printing, which need to be debugged twice

Click Head Space → Print Adjust

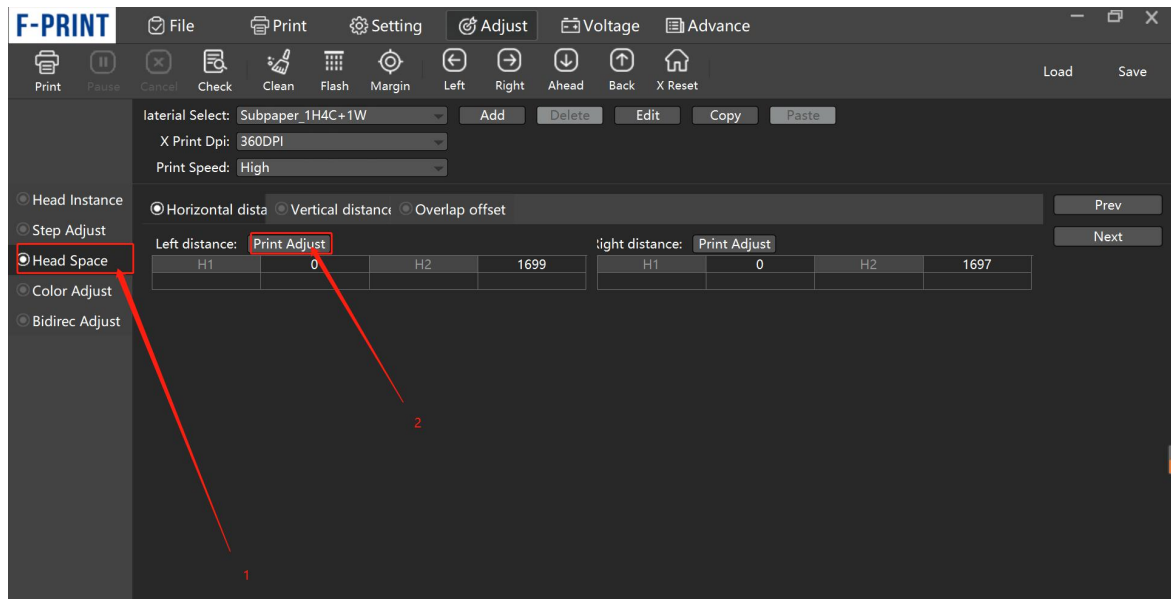

Check the printing effect

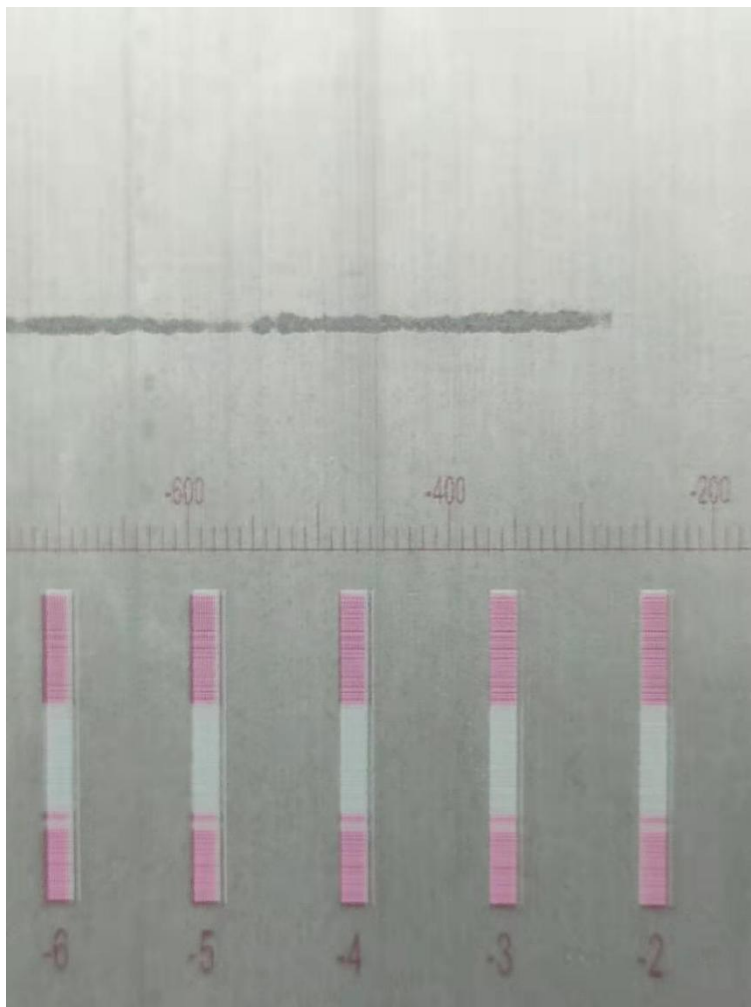

For example, the position of -3 in the figure, white and color are overlapped, then the label position in the figure below is reduced by 3, and then click save. Same as step calibration, repeated testing knows that the position of 0 is overlapped

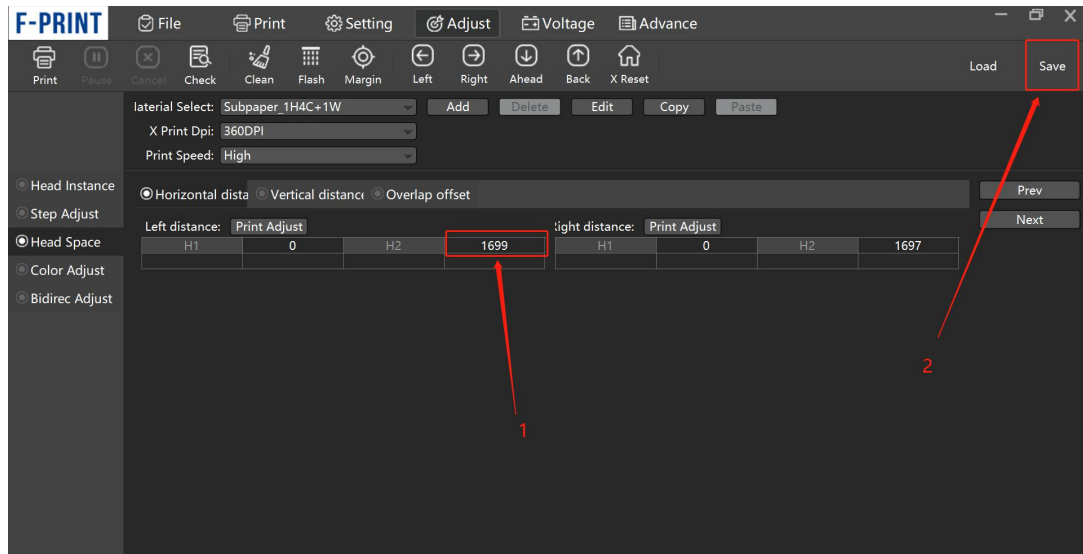

Then print to the right, the debugging method is the same as to the left

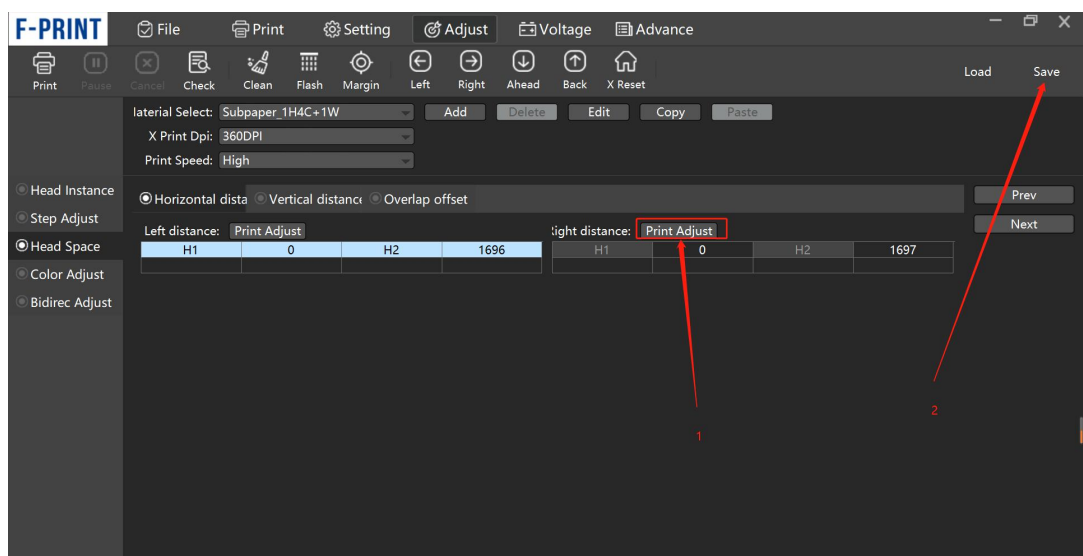

The fourth step, Vertical distance

Click Vertical distance → Print Adjust

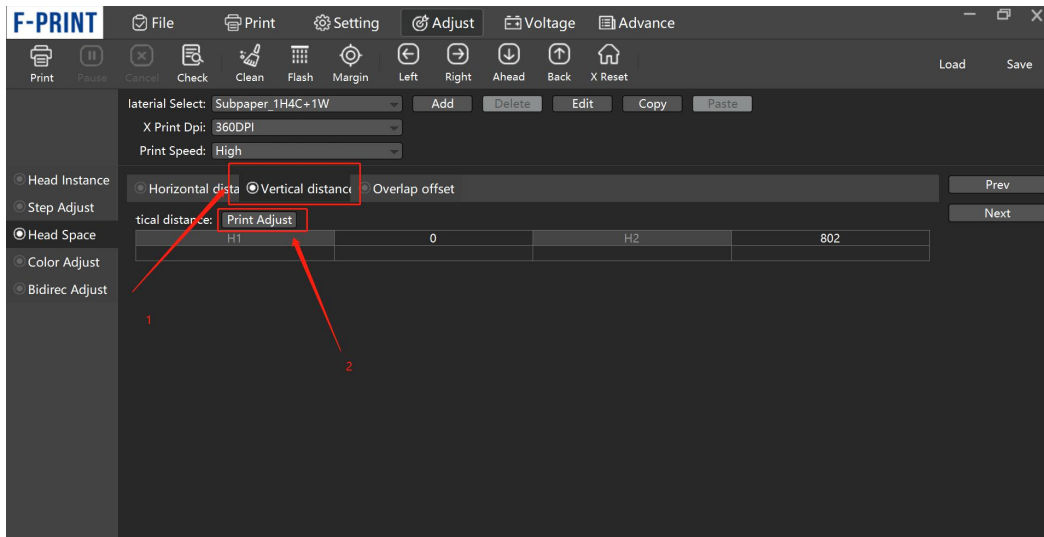

Check the print result, as shown in the figure, the white lines of -2 and -6 are not parallel to the color, and -4 is relatively parallel.

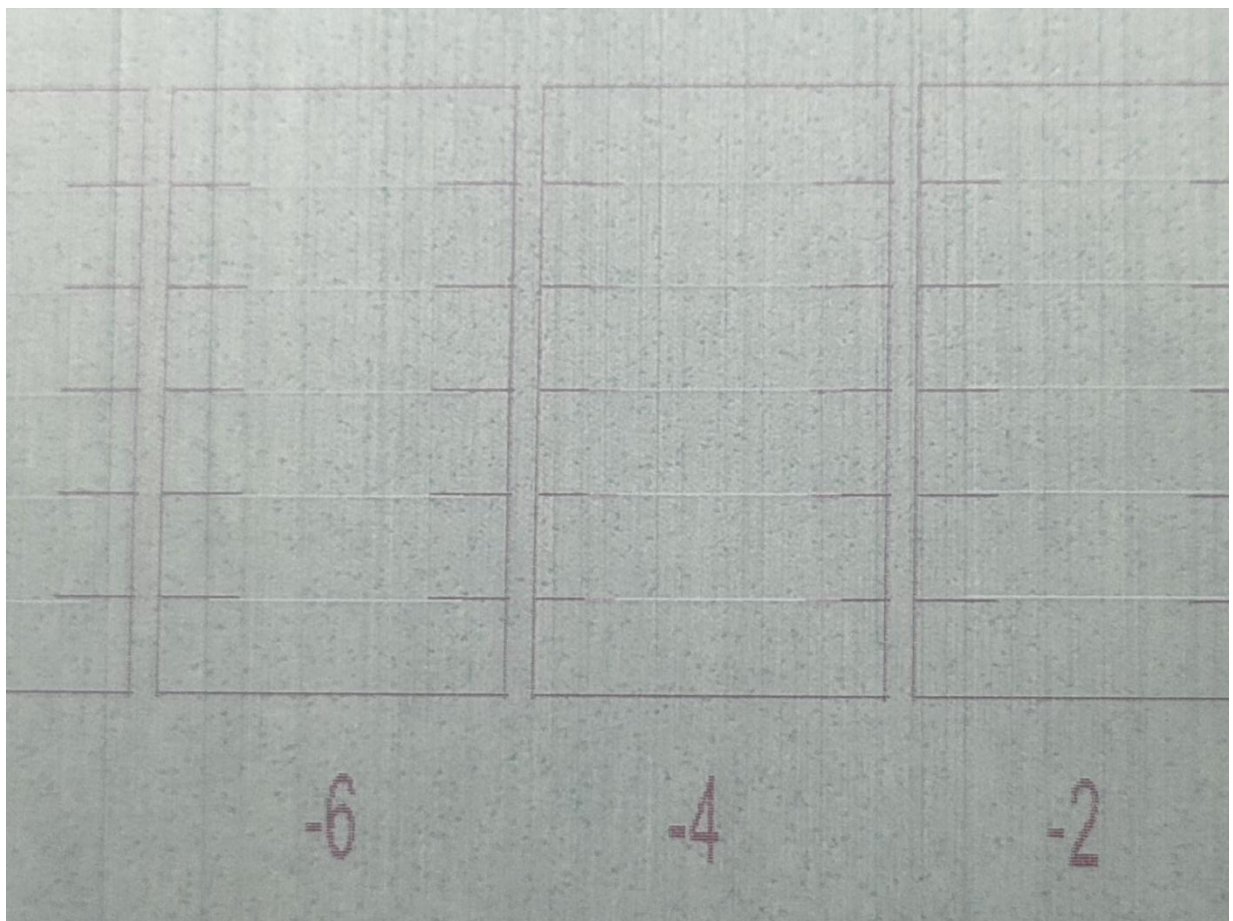

Decrease 4 in the marked position in the figure, click Save, and repeat the print test until the 0 position is parallel

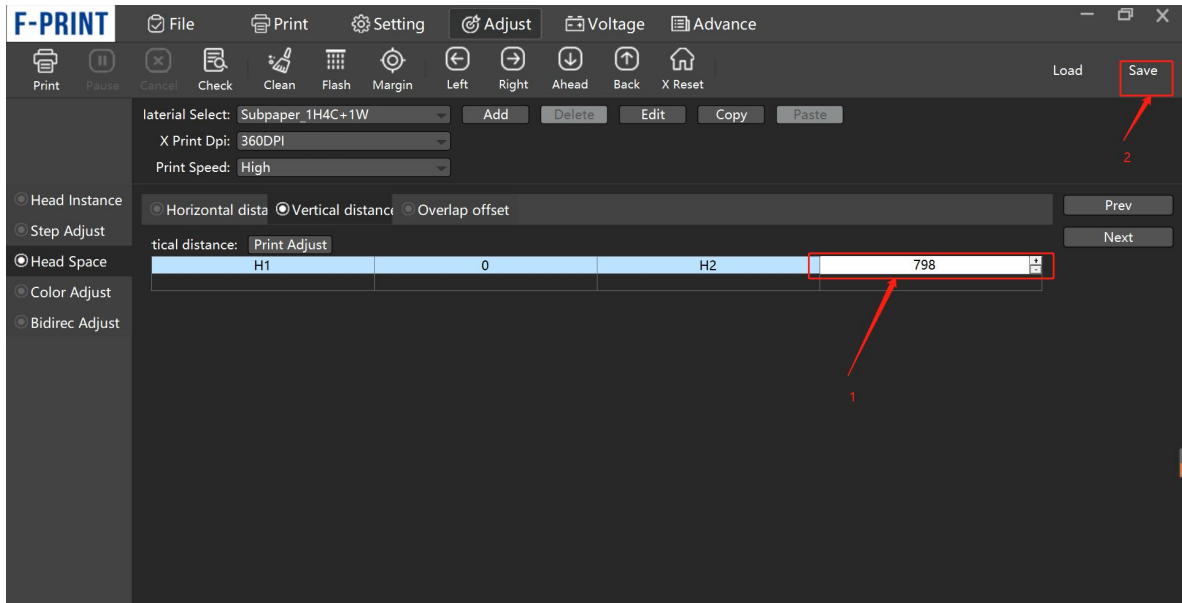

The fifth step, bidirec adjust

Bidirec Adjust → Print Adjust

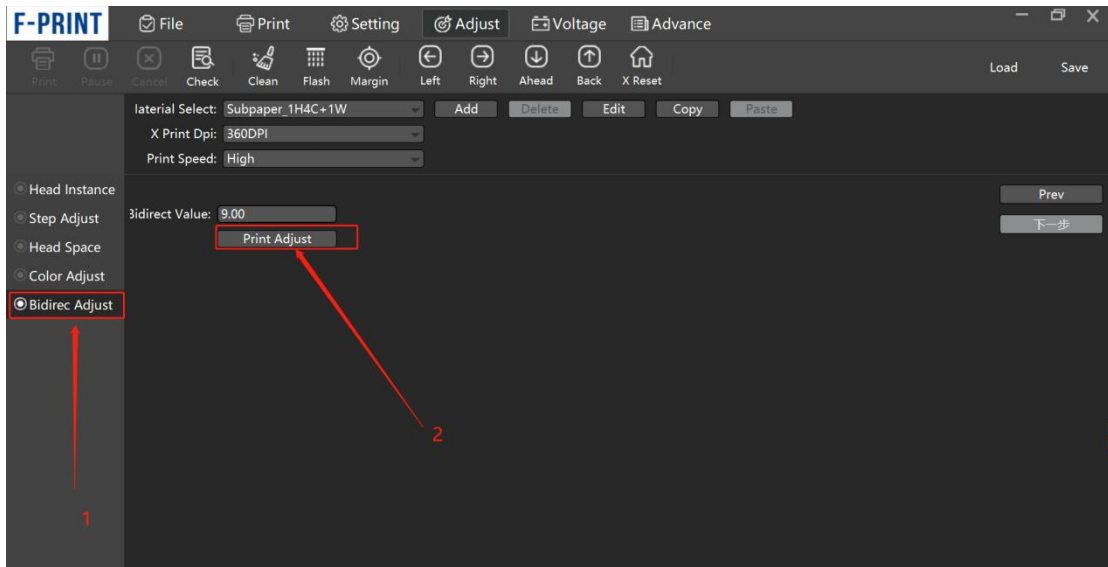

View print results

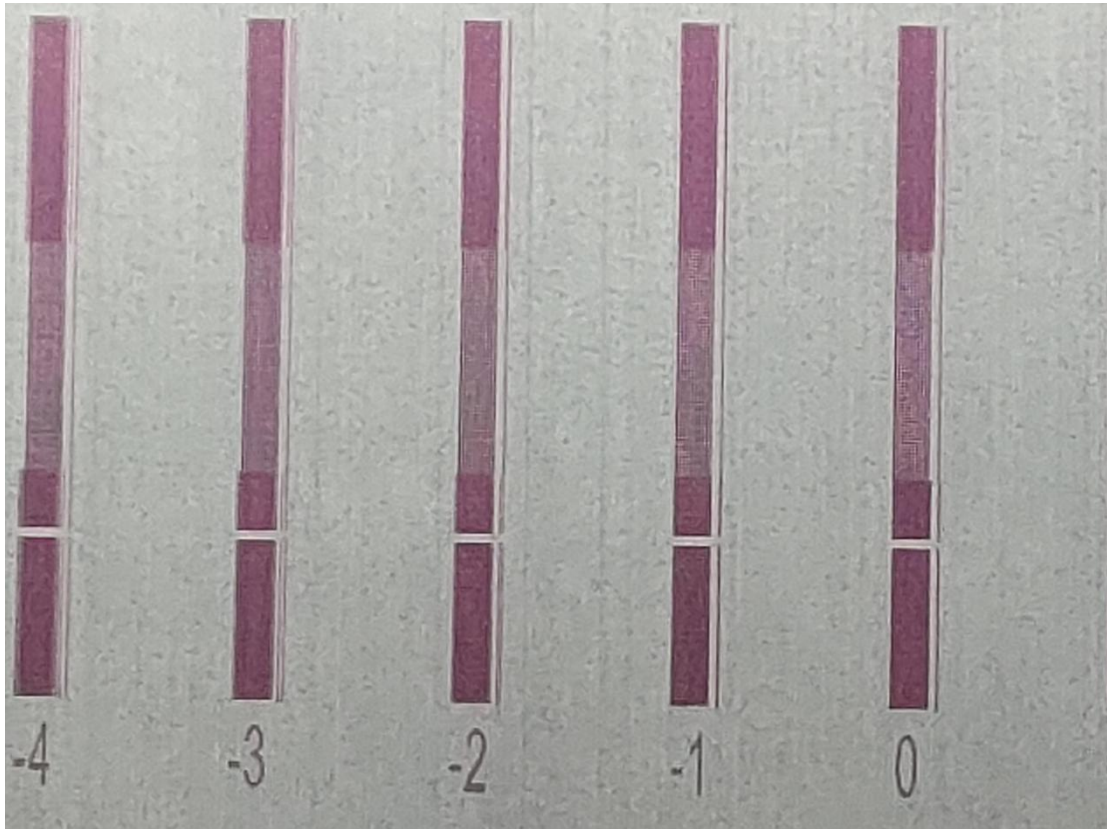

Look at the thin lines in the picture. For example, at the -3 position, you can see that the thin lines are separated, and the -1 part is overlapped. So reduce by 1 in the place marked in the picture, click save, and then print again to test until 0 Location is the best

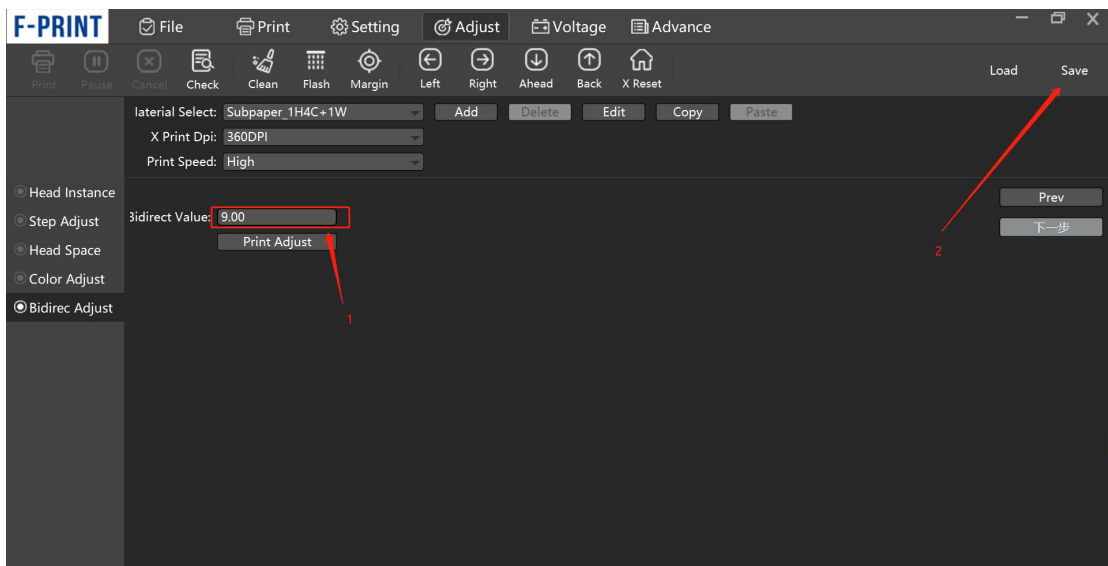

T602

2-head DTF Pinter

Instruction Manual



XINFLYING

Reliable & Professional Printing Machine's Supplier Since 2010

○ Thank you for purchasing this product
Please read this manual carefully before use ○ Please keep this book properly

Catalogue

1. Introduce	2
2. SAFETY INSTRUCTIONS	3
2.1 Safety indications and their meanings	3
2.2 Note for safety	3
3. Preparations and Precautions	5
3.1. Unpacking Your Printer	5
3.2. Required Printing Environment Condition	5
3.3. Electrical Requirements	5
3.4. Computer configuration requirements:	5
3.5 Heat Press:	5
3.6 Precautions	6
4. Product Introduction	7
5. Model specification	7
6. Product show and rack installation	8
7. Software Installation and Set up	10
7.1 Printing software installation	10
7.2 Connect Gigabit Network Cable	11
7.3 Set the online IP address of the printing software	11
7.4 RIP software installation	13
8. Printer Installation and Pre-print Debugging	14
8.1 Horizontal Calibration	14
8.2 Ink Tank Connection	14
8.3 Print Head Installation position and cable connection	15
8.4 Damper Installation	21
9. Power-on inspection	21
10. Debug Before Printing	22
10.1 Confirm ink stack and cleaning parameters	22
10.2 Print Nozzle Test & Confirm the status of Print Head	22
11. Alignment & Calibration	24
11.1 Vertical Alignment Of the Print Head	24
11.2 Step calibration	24
11.3 Calibration of nozzle horizontal space	25
11.4 Nozzle vertical space calibration	26
11.5 Bidirectional printing calibration	27
12. Optional Device	29
13. Precautions & Maintenance	30

1. Introduce

Dear Sir/Madam:

Thank you for choosing our products, we are a highly professional and reliable supplier of DTF printer.

DTF printer is an advanced technology product that has developed rapidly in recent years. In order to help our users better operate the machine and ensure its normal operation, this manual will provide detailed instructions on how to use, maintain and precautions of the DTF printer. Please read this manual carefully before using the machine and follow the guideline for proper operation. If you have any questions, please contact our technical engineers for guidance. This equipment is suitable for temperature of 20 ~ 35°C/68 ~ 95°F and humidity levels of 35 ~ 70%RH, which can improve production efficiency and product quality.

This manual is only the product usage instructions. If there are any upgrades to the machine, we will not notify separately. If you have any good suggestions for this product, please provide feedback to the agent so that we can get the information in time and make better improvements to the machine

Thank you!



2. SAFETY INSTRUCTIONS

2.1 Safety indications and their meanings

This instruction manual and the indications and symbols that are used on the printer itself are provided in order to ensure safe operation of this printer and to prevent accidents and injury to yourself or other people.

The meanings of these indications and symbols are given below.

Indications

	DANGER	The instructions which follow this term indicate situations where failure to follow the instructions may result in death or serious injury.
	WARNING	The instructions which follow this term indicate situations where failure to follow the instructions can result in severe injury or death.
	CAUTION	The instructions which follow this term indicate situations where failure to follow the instructions could cause injury when using the machine or physical damage to equipment and surroundings.

2.2 Note for safety

Symbols



.....

This symbol () indicates something that you should be careful of. The picture inside the triangle indicates the nature of the caution that must be taken.

(For example, the symbol at left means “beware of injury”.)



.....







This symbol () indicates something that you must not do.



.....

This symbol () indicates something that you must do. The picture inside the circle indicates the nature of the thing that must be done.







(For example, the symbol at left means “you must make the ground connection”.)

 DANGER	
 Wait at least 5 minutes after turning off the power switch and disconnecting the power cord from the wall outlet before opening the cover of the control unit. Touching areas where high voltages are present can result in severe injury.	
 WARNING	
Basic precautions	
 Do not disassemble or modify the printer, otherwise it may cause fire or electric shocks or problems with correct operation.	 Do not handle the power cord with wet hands, otherwise it may cause electric shocks.
 Ask the place of purchase or a qualified technician to carry out any internal inspections, adjustments or repairs that may be required. (Any problems with correct operation that occur as a result of the customer attempting to disassemble or modify the printer will not be covered by the warranty.)	









CAUTION







Installation

-  Setting up and moving of the printer should only be carried out by a qualified technician.
-  The printer machine weighs approximately 150 kg. Transporting and setting up of the printer should be carried out by four or more people.
-  Furthermore, do not hold the printer by the ink cartridge housing when transporting it, otherwise the ink cartridge housing may become damaged and the printer may fall down and cause personal injury or damage to the printer.
-  Do not place the printer on unstable surfaces such as unsteady tables or high shelves, otherwise it may tip over or fall down and cause injury. Furthermore, the table that supports the printer should be able to bear a weight of 150 kg or more.
-  Do not set up the printer in a place where it will be affected by vibration from other equipment, otherwise it may become unbalanced and fall down and cause injury or damage to the printer.
-  Do not connect the power cord until setup is complete, otherwise the printer may operate if the power switch is turned on by mistake, which could result in injury.
-  Do not climb onto the printer or place heavy objects on top of it, otherwise it may become unbalanced and tip over or fall down and cause injury.

Printing

-  This printer should only be used by operators who have received the necessary training in safe use beforehand.
-  Leave sufficient space at the front of the printer, and avoid placing items in front of it, otherwise the platen may hit them and be damaged, and if your hands get caught between the platen and the object, injury may result.
-  Release your hand from the platen while the printer is operating. If your hand gets caught between the platen or the T-shirt tray and the covers, injury may result.
-  Do not push nor pull the platen by hands quickly. It must be a cause of operation troubles or failures of printed circuit boards.
-  Do not put your hands inside the covers while the printer's power is turned on, otherwise your hands may touch against moving parts and this may result in injury.
-  If a problem occurs with the operation of the printer, contact the place of purchase or a qualified technician.

Maintenance

-  Wait at least 1 minute after turning off the power switch before opening the front cover. Touching the heat sink on the head can result in burns.
-  Be careful not to get your fingers caught when closing the front cover, otherwise it may result in injury to your fingers.
-  Do not push nor pull the platen by hands quickly. It must be a cause of operation troubles or failures of printed circuit boards.
-  Do not disassemble the ink cartridge or the waste ink cartridge. If the ink cartridge or waste ink cartridge is disassembled, it can no longer be used.
-  Take care not to let the ink, waste liquid or wash liquid come into contact with your eyes or onto your skin, otherwise inflammation can result. Furthermore, do not drink the ink, waste liquid or wash liquid under any circumstances, as they can cause vomiting and diarrhoea. Keep the ink, waste liquid and wash liquid out of the reach of children.
-  Use only the proper replacement parts as specified by Xinflying.

3. Preparations and Precautions

3.1. Unpacking Your Printer

After unpacking, check all your parts are included.
Contact XINFILYING if any of these is missing.

3.2. Required Printing Environment Condition

The printing environment request 20°C-35°C (68°F - 95°F) and 35-70%humidity.

3.3. Electrical Requirements

Please check whether your printer's voltage is match your voltage that your country use. If it doesn't match, it will lead to an explosion!

3.4. Computer configuration requirements

Computer system:

Windows10/64 -bit, Windows11/64 -bit.

CPU configuration:

Use i5 or above i5 CPU.

Memory stick:

8G or above

Power supply:

500W or above

Motherboard:

Configure the USB 3.0 port, gigabit network card

Network card and network cable requirements:

Gigabit or above network card must be used, and the network cable needs to be super Category 6 or above to support dry-mega communication network cable.

Hard disk configuration:

It is recommended to use a 120G solid state hard disk as the system disk, and then add a mechanical hard disk (1TB) as a secondary disk as needed.

Based on PCIe system, Asus / Gigabit etc.

3.5 Heat Press

It is recommended the heating temperature up to 150-160 °C(302°F - 320 °F) for 6-10 seconds.

3.6 Precautions

1. The machine foot holder cup must be secured to keep the machine level to ensure that the machine does not shake.
2. Do not let liquids come into the print head and cables, as it can damage the print head.
3. Avoid scratching the print head with the printing film, as it can be fatal to the print head.
4. Before shutting down, check if the trolley is reset to ensure the print head is in the optimal position (in the middle of the ink pad). The print head must be aligned with the ink pad to maintain moisture and prevent clogging.
5. The print head cable must be correctly connected and double-checked before starting the machine. Send pictures or videos of the cable connections to the technicians. Incorrect connections can damage the print head or head board.
6. After turning on the machine, please open the white ink circulation system and let it run for 2-3 minutes before closing. This effectively prevents the formation of bubbles in the ink tubes.
7. Do not let the pet film scratch the printer head, which is deadly for heads. So the press clips on both sides of printing platform should be pressed onto printing film, covering a space of 2-3mm.
8. Keep consumables away from direct sunlight and humid environment. For optimal printing results, it is recommended to use them within the warranty period, which is one year.
9. Ink can cause ink tube blockages. To avoid this, open the printer at least once a week and clean the print head by pressing the nozzle cleaning button. If you plan not to use your printer for more than two weeks, follow the maintenance manual to prevent ink blockages.
10. The Color Bar should be set "Wetting" by the software to prevent the print head from clogging.
11. Do not unplug any wires from the machine while it is powered on, as it can damage the boards and print head.
12. The machine must be grounded to prevent ink splattering or damage to individual ink dots on the print head.
13. Do not manually cut printing film on the machine with a knife or other sharp article, as it can cause scratches and affect the appearance of the machine.

4. Product Introduction

The Transfer Printing White Ink Machine, which uses Epson I3200-A1 print head with high precision, high efficiency, and finer colors. The product supports personalized customization for DIY purposes and has a wide range of applications. The machine is easy to operate and maintain, equipped with a white ink circulation system to ensure smoother ink flow and prolong the life of the print head.

5. Model specification

Model Type	T-602
Print head and Quantity	I3200-A1 2pcs
Printing Resolution	2400DPI
Printing Speed	4pass:12m ² /h 6pass:10m ² /h
Printing Width	0.6M
Media Type	Pet film
RIP Software	Standard software: Maintop; Optional: CADlink ,PrintFactory, Photoprint(Flexi)
Temperature/Humidity	Temperature: 20-35°C/68 ~ 95°F, Humidity: 35-75%RH
Power	350W
Machine Dimension	Machine size : 1755mm*770mm*1600mm(L*W*H)
	Package size : 2135mm*875mm*780mm(L*W*H)
Machine Weight	Net weight: 150KG ; Gross weight):210KG

6. Product show and rack installation

First, install a single leg rack, screw the pulleys and foot holder on the base, and then assemble the bracket with fastener and base. After the two leg rack are assembled, connect the two leg rack with beams to complete the leg rack installation.

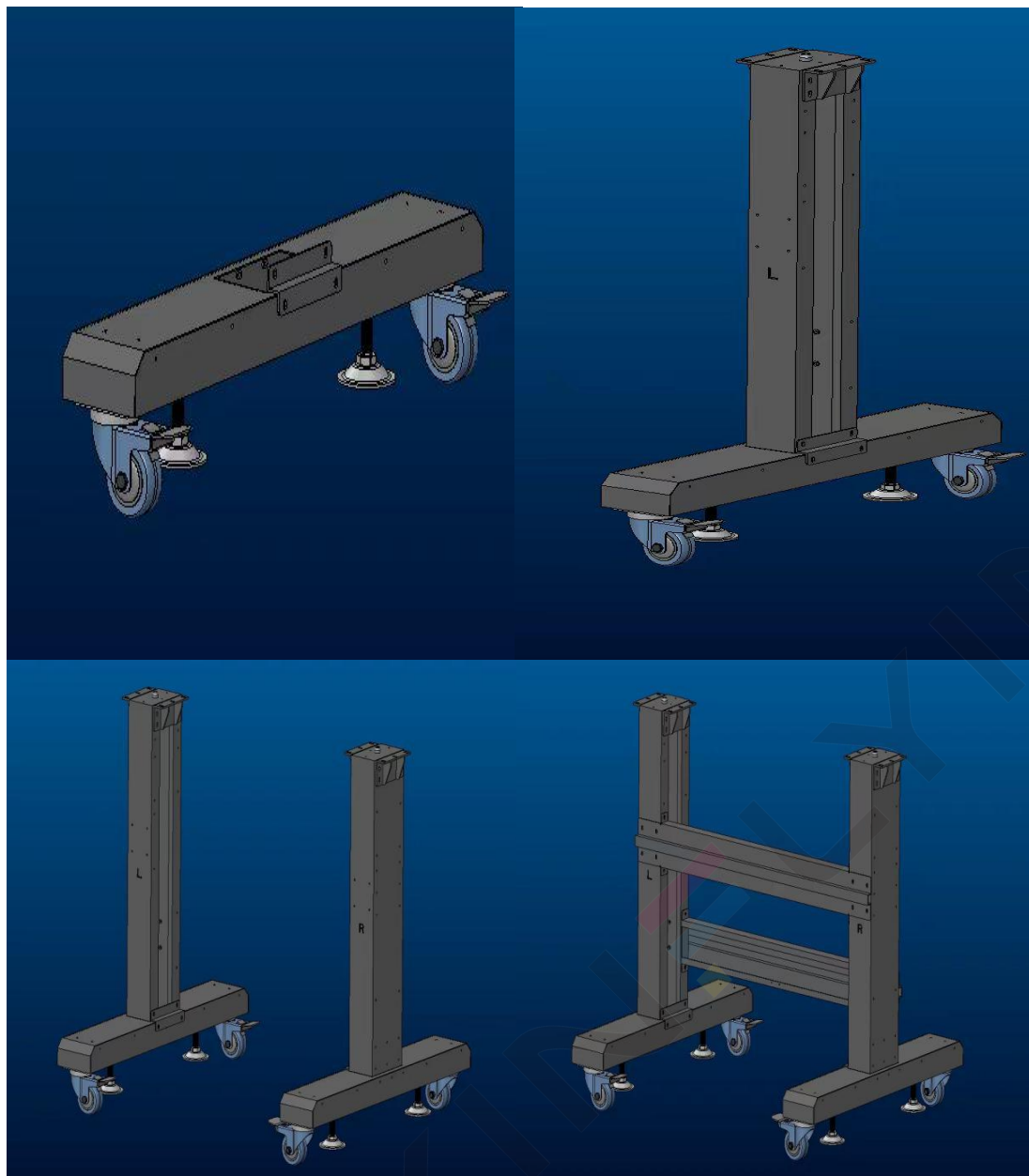

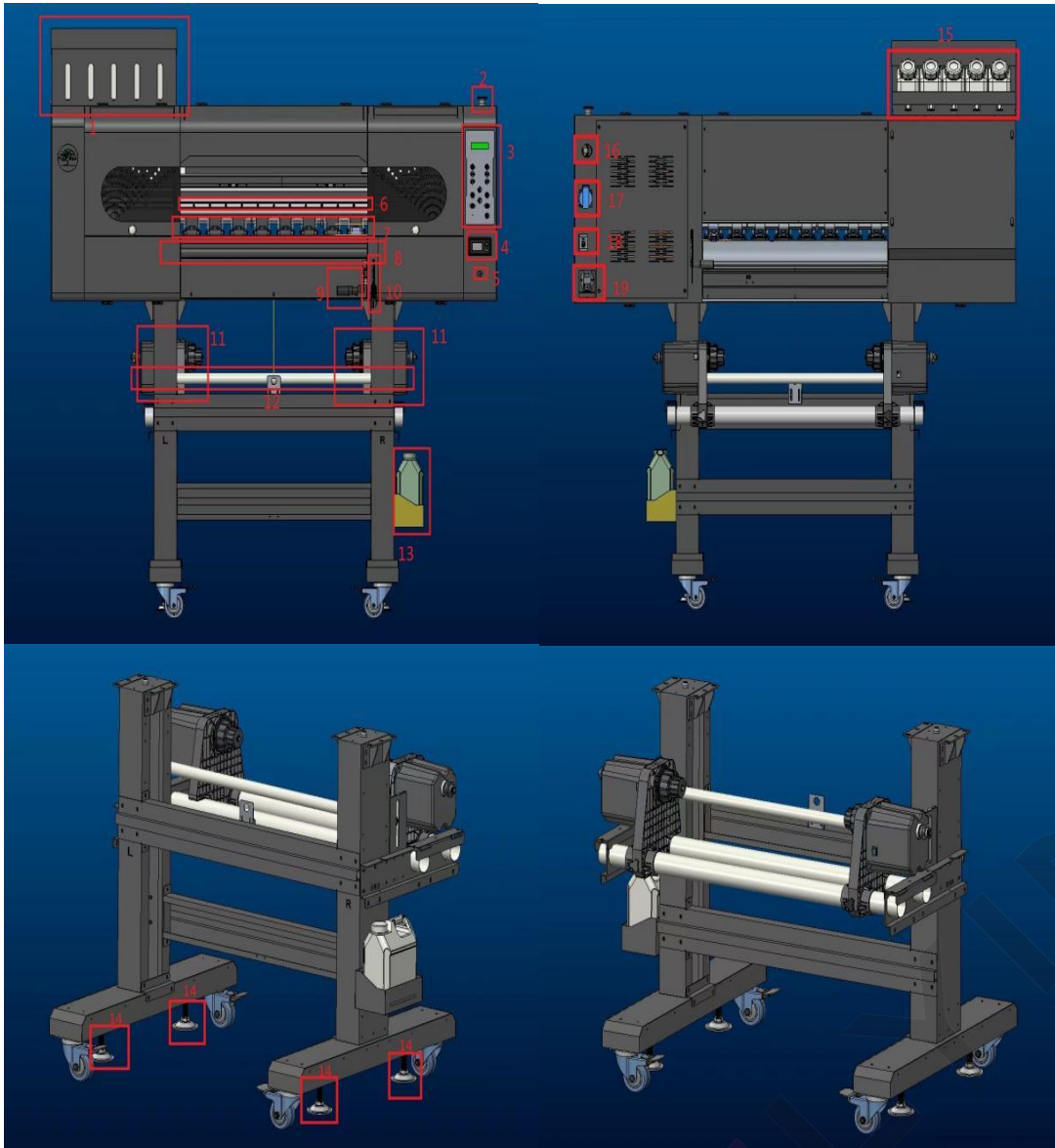

NO.	Name	NO.	Name
1	Ink shortage alarm system	11	Paper feeder
2	Emergency stop switch	12	Paper pressing rod
3	Control panel	13	Waste ink tank
4	Temperature control panel	14	Foot holder
5	White ink circulating knob	15	Ink tank
6	Guide rail	16	Network cable connection port
7	Pinch roller	17	Standby power socket (like computer connection, paper feeder etc.)
8	Printing platform	18	Residual Current Device (RCD)
9	Pinch roller handle	19	Main power supply Socket
10	Lifting Pinch roller handle		

7. Software Installation and Set up

7.1 Printing software installation

1) Unzip the installation package to find the installation file.



2) Select the language and set the installation path

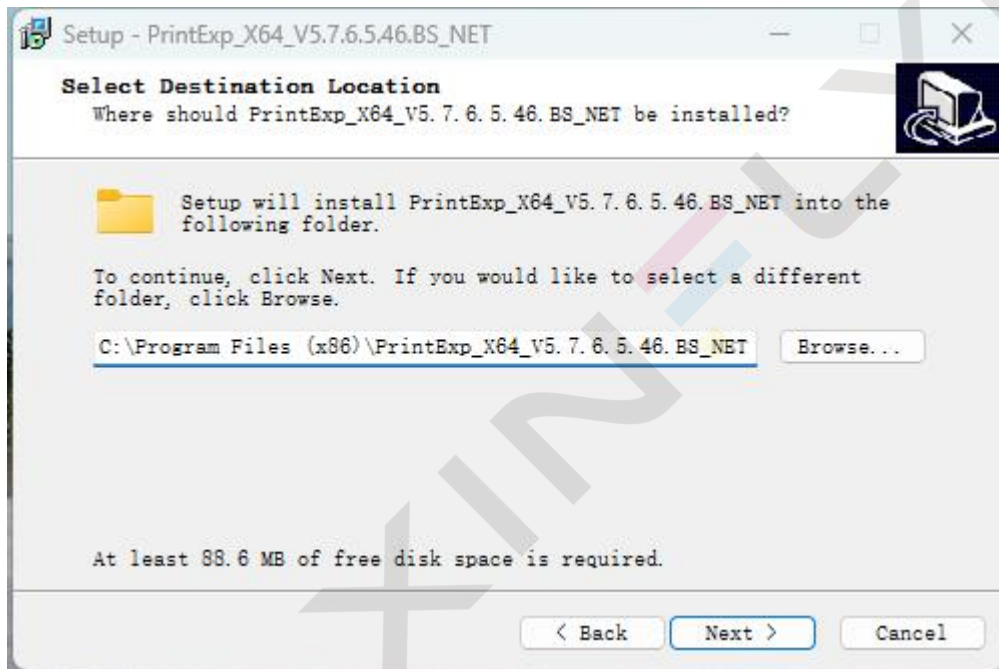
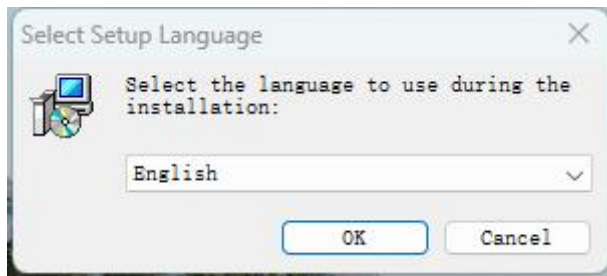

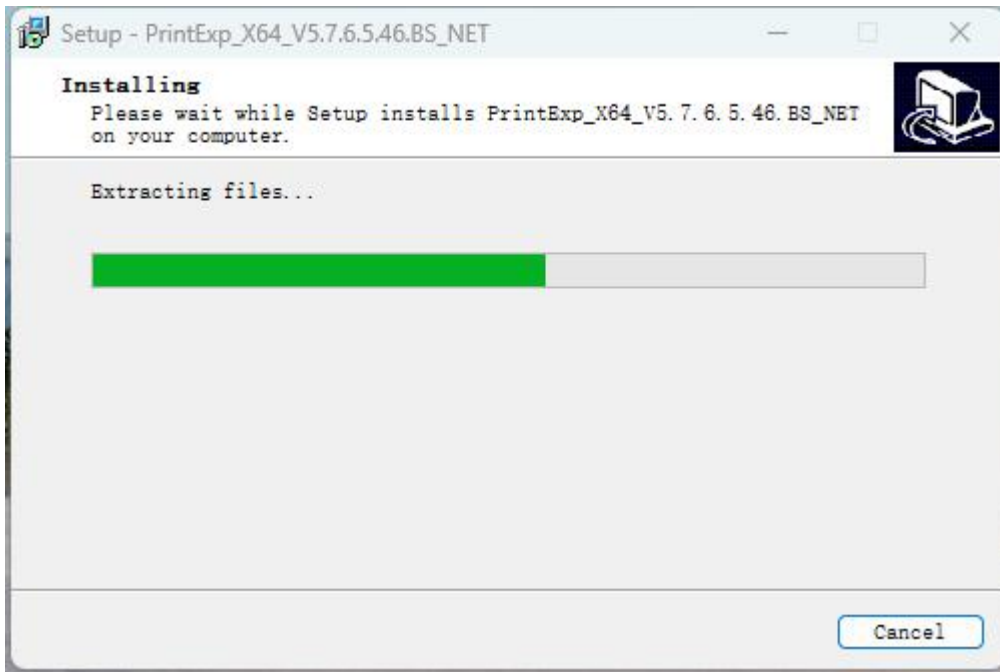

3) Create a desktop shortcut.

PrintExp_X64.exe

7.2 Connect Gigabit Network Cable

We will equip the machine with a gigabit network cable. Then we connect one end of the gigabit network cable to the network port of the printer motherboard, and the other end to the network port of the computer host.

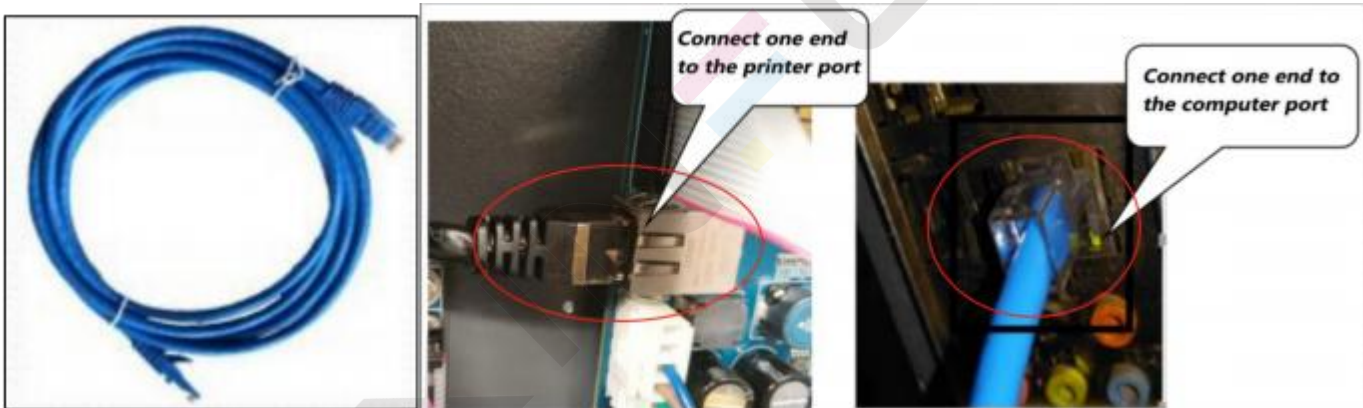

7.3 Set the online IP address of the printing software

Before connecting to the network, please check if your computer is equipped with a gigabit network card to ensure a smooth connection. The difference between a gigabit network card and a 100Mbps network card is as follows: Gigabit network cards usually have the following characteristics: Gigabit, GBE, 10/100/1000M, RTL8169.

100Mbps network card contains the following characters: Fast Ethernet, 10/100, FE.

Enter the computer's device manager to check the network adapter.

The control software version must match the board version. After installing both the control software and RIP software according to the instructions in the installation package, you can configure the IP settings for networking. Here are the steps to follow: Open the software → Network and Internet setting → Communication set → TCP communication → Enter the local host IP: 192.168.127.11 → Control Panel → Network and Internet → Network connections → Right-click on 'Properties' → TCP/IPv4 → Click on 'Properties' → Check 'Use the following IP address' and modify the IP address to 192.168.127.11. (About this, we have a tutorial introduction document we sent to you)

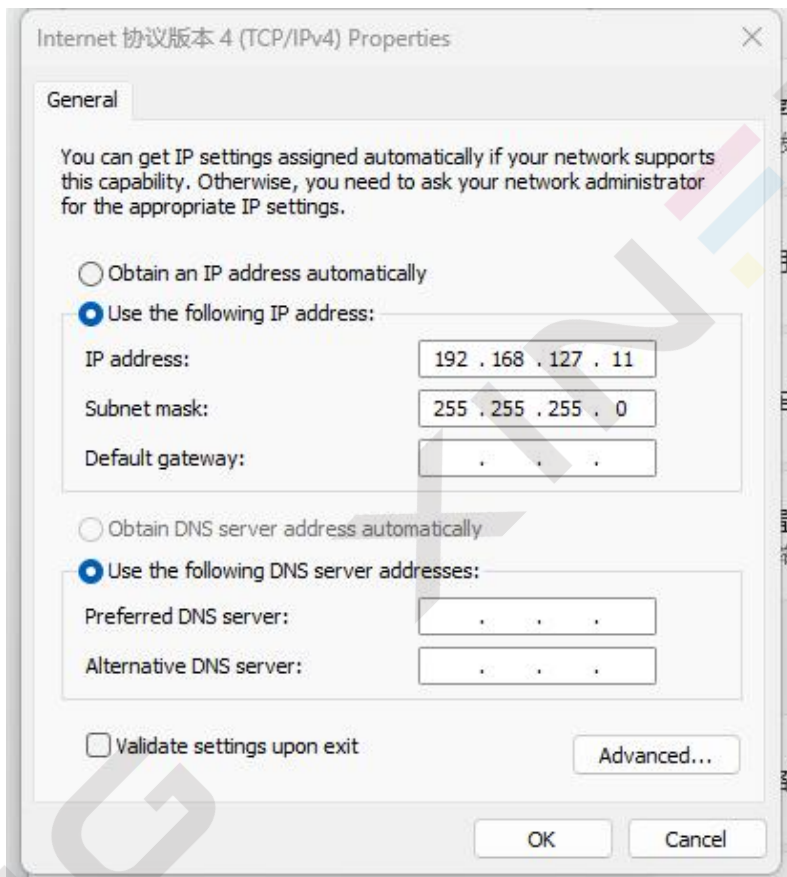
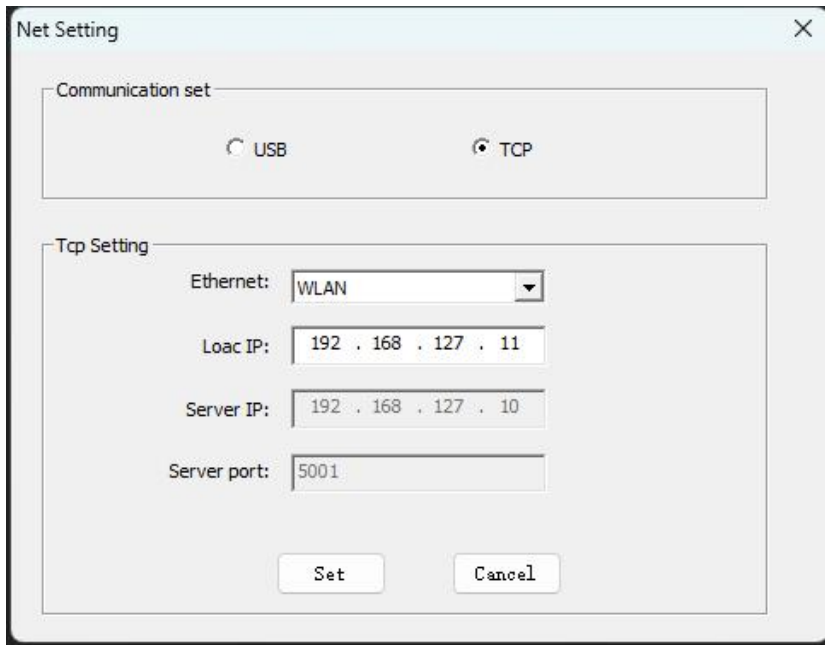

7.4 RIP software installation

The DTF printer mainly uses RIP software, which includes Maintop, PrintFactory, Photoprint(Flexi). This chapter will use Maintop as an example to introduce the installation method of RIP software.

1. Extract the installation package and locate the installation file

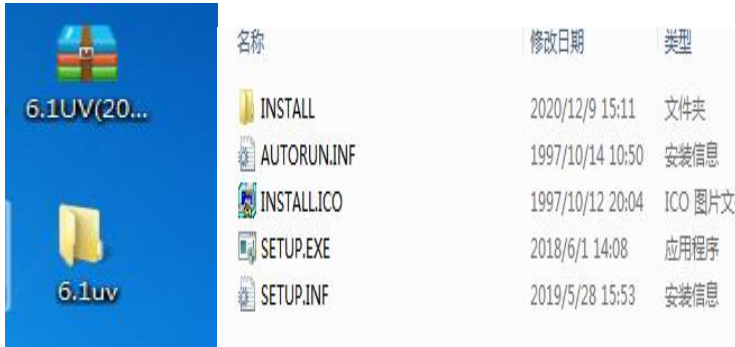

2. Set the installation path and wait until the installation is complete.



3. Finish the installation and create a desktop shortcut.



8. Printer Installation and Pre-print Debugging

8.1 Horizontal Calibration

Fix the foot cup and use a level to align the steel pipe. The calibration of the printing platform should have an error value within ± 0.1 to prevent material deviation. Please refer to the picture for details.

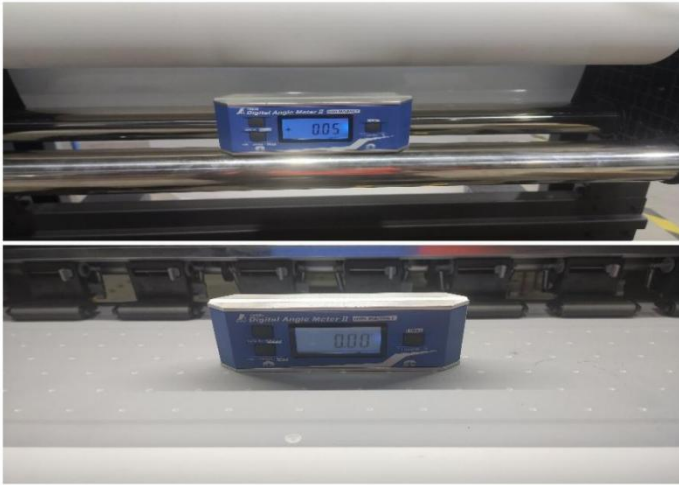

8.2 Ink Tank Connection

1. Install and tighten the screws on the ink tank, then put the ink tank in order, connect the ink tube to the corresponding color ink tank, and insert a clip in the middle of the ink tube (The clips can be used for the printer after disconnecting the power, the clip clamps the ink tube to prevent ink from flowing and leaking).

2. The white ink tank has two connection ports. The ink tube on the white circulation pump is inserted into the top outlet of the white ink tank. The other ink tubes should be connected to the under outlet of the corresponding ink tank. There are color labels on the ink tubes, which should be connect to the corresponding colors.

3. When connecting, remember to put on the ink tube clips. Like the picture shows.

Note: No adding ink when the ink tube and damper are not connected.

Remember to clip the ink tubes.



8.3 Print Head Installation position and cable connection

Take out the print head and its cover , use a syringe insert into the four ink holes above the print head respectively. Gently flush out the moisturizer inside the print head. Gently wipe the surface of the print head with a dust free cloth, install back the print head cover. Connect the print head cable, and stick the connection between the cable and the print head with special waterproof tape. Gently align the print head with the holes and screw it, the screws are just tight enough.

NOTICED:

- ① You can't use a large syringe, use a 2.5ml small syringe to lightly flush out the moisturizer. Cleaning the print head also use a 2.5ml small syringe.
- ② The cables should be aligned and inserted with appropriate force. Don't use excessive force or insert it crookedly, and make sure it is not inserted in the wrong orientation.
- ③ When connecting the cables, pay attention to whether the metal part of the cable is bent or broken.
- ④ DO NOT scratch the surface of the print head to prevent damage to the print head; Note that the bottom of the print head should not be touched (Red circle mark is the bottom of the print head), because the bottom of the print head is very fragile.



- ⑤ The screws on the print head should be properly tightened, and DO NOT tighten too much to prevent damage to the screw holes and damage to the print head.

1. Installation of the cables, the print head should be connect with two 14P cables on the left and the right.

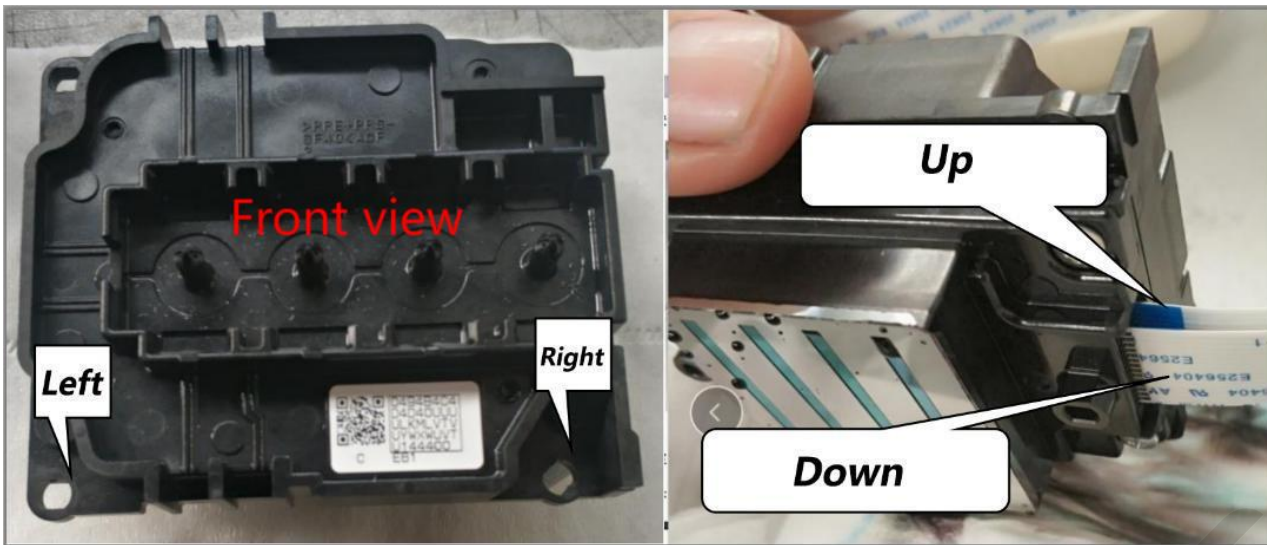

(Note: Be careful when plugging in, so as not to damage the print head or the cables!)



2. Install the print head

Put the print head steadily to the left and back, close to the bottom plate, and install and secure it. (Note: Do not tighten the print head mounting screws too hard)



Schematic diagram

The order of cable connections corresponds to the markings on the cable headboard and the print head.

(Note: When plugging or unplugging the print head cable, do not turn on the printer. Please remember that reversing the cable of the print head is not allowed as it will damage the print head!)

This is the schematic diagram of the connection of the print head 4720 and I3200

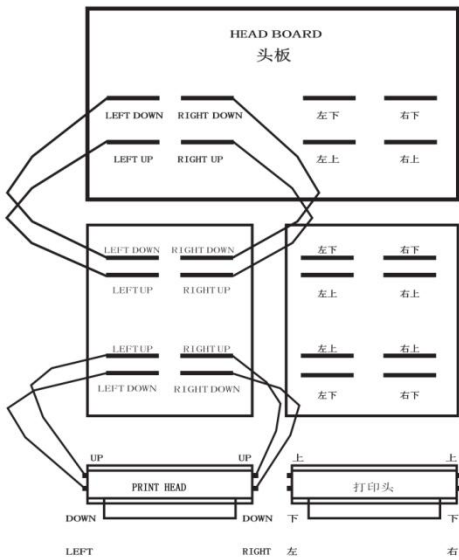

4720 print head connection

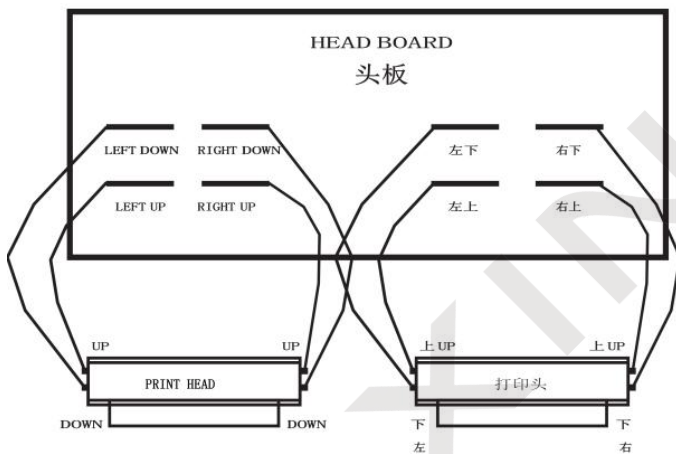

I3200 Print head connection

I3200 Print head



Correct(metal part to metal part)

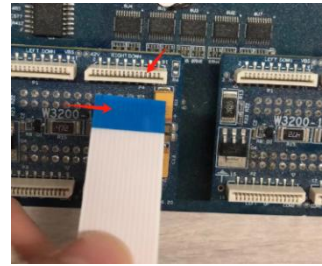

Incorrect

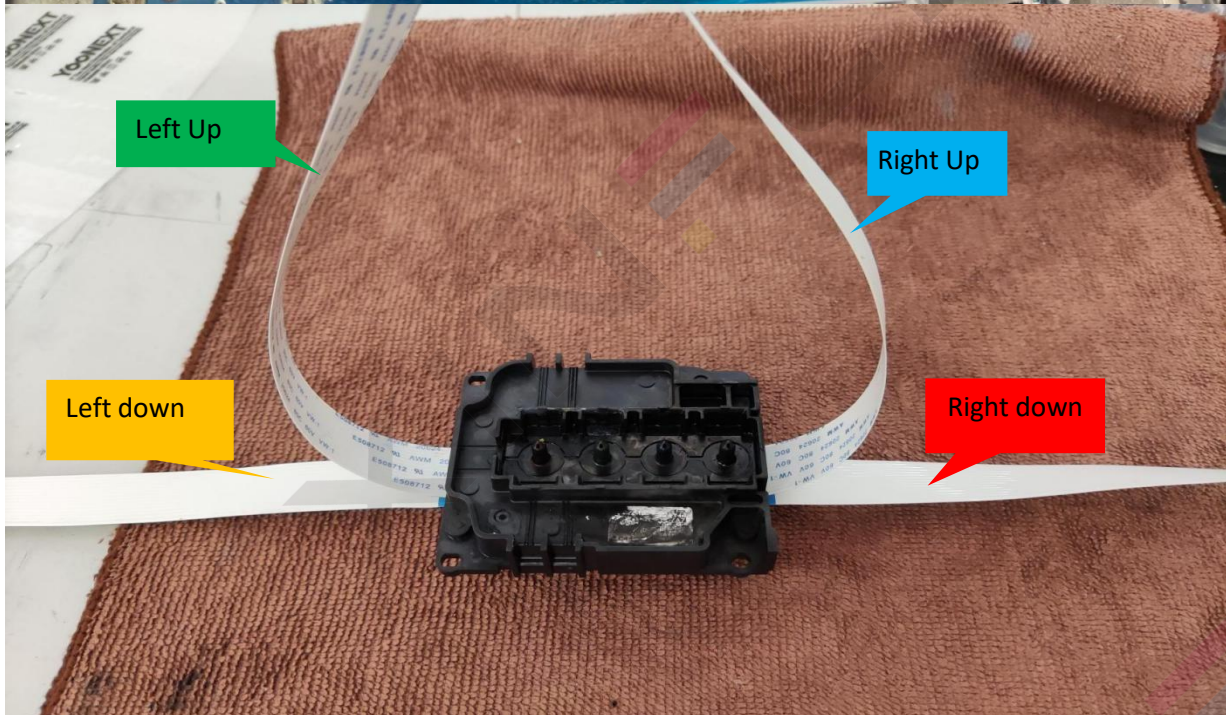
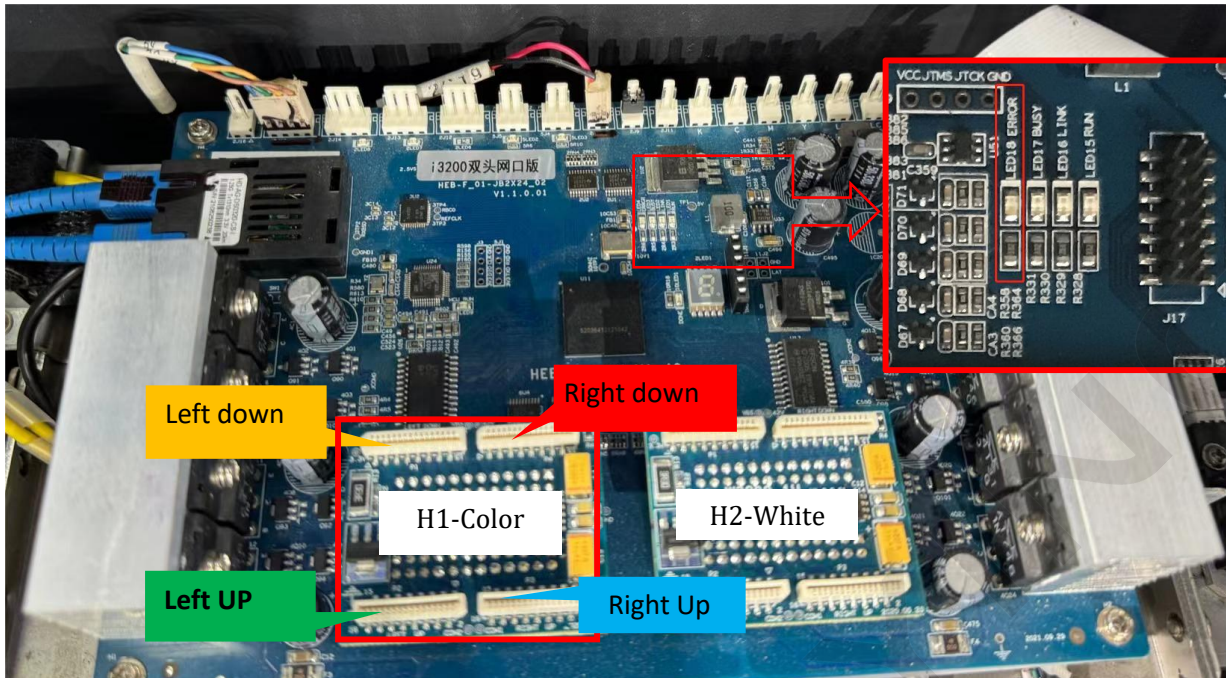

After confirming the print head's cables are connected correctly, (You need to take photos or record video to our technicians for checking so that you can turn the printer on! And observe whether the "ERROR" light on the head board is on. If the light is on, it is abnormal. Turn it off immediately and check.

4720 Print head

The Diagram of the Cables Connection of the Head Board and the Decoder

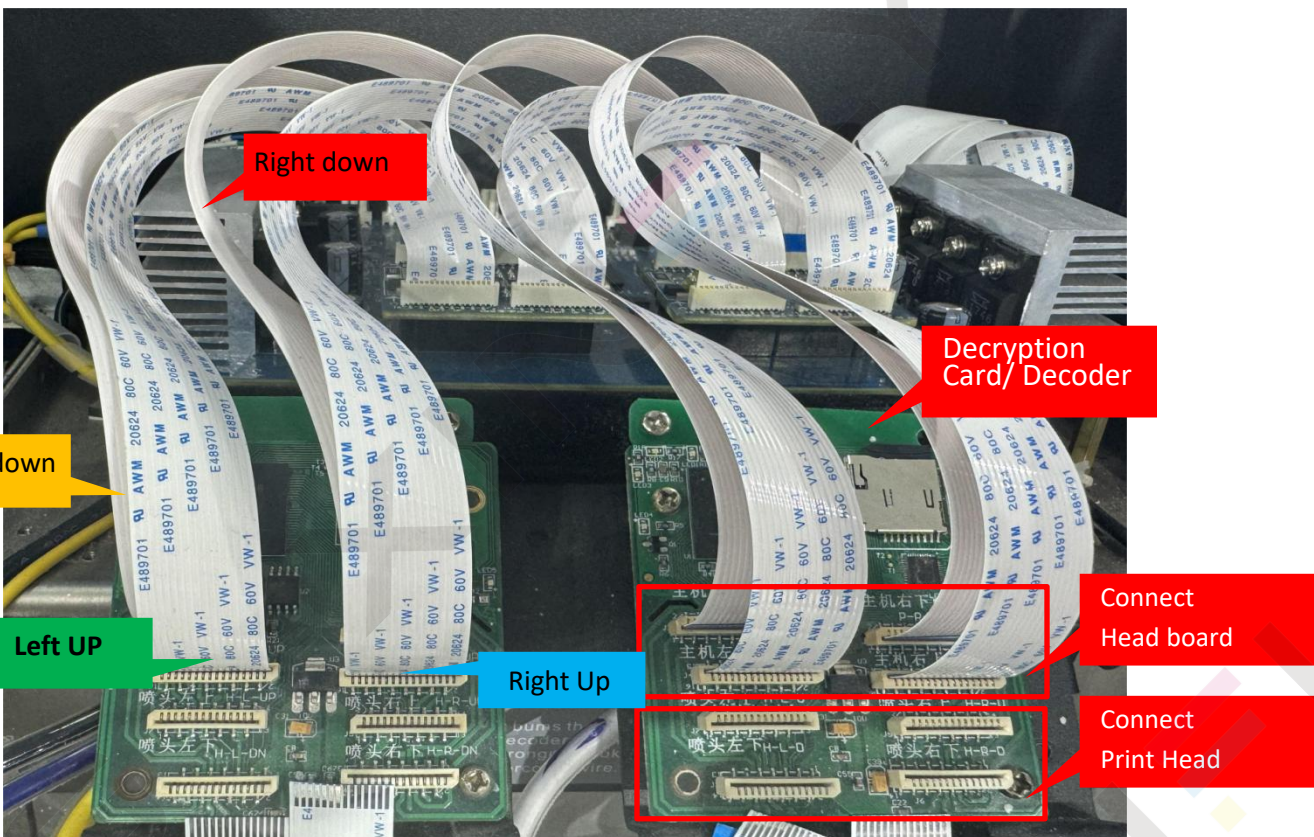
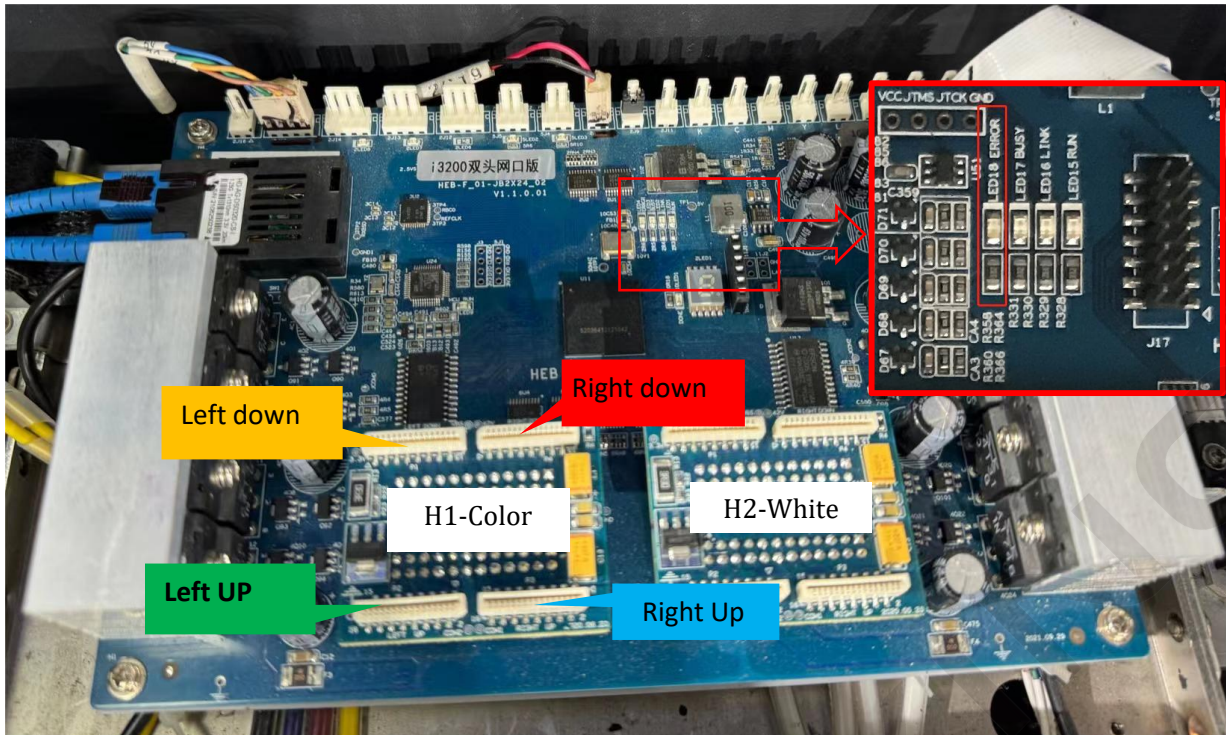

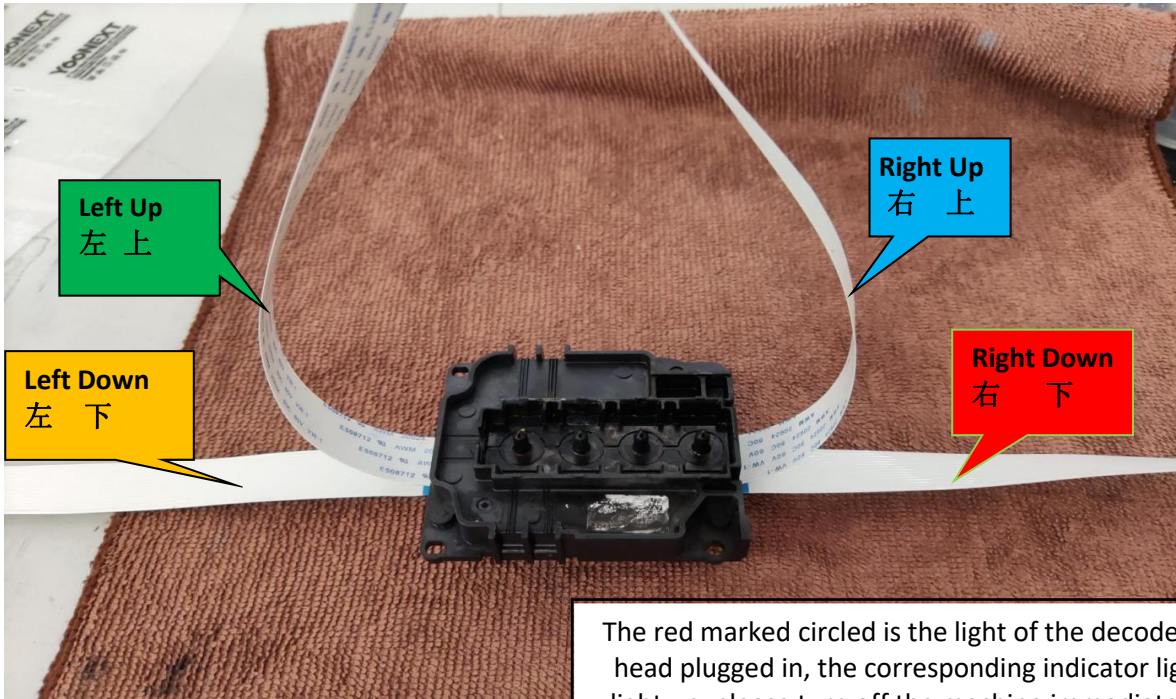

The red marked circled is the light of the decoder. If the print head plugged in, the corresponding indicator light does not light up, please turn off the machine immediately and make sure that the cable is connected correctly.

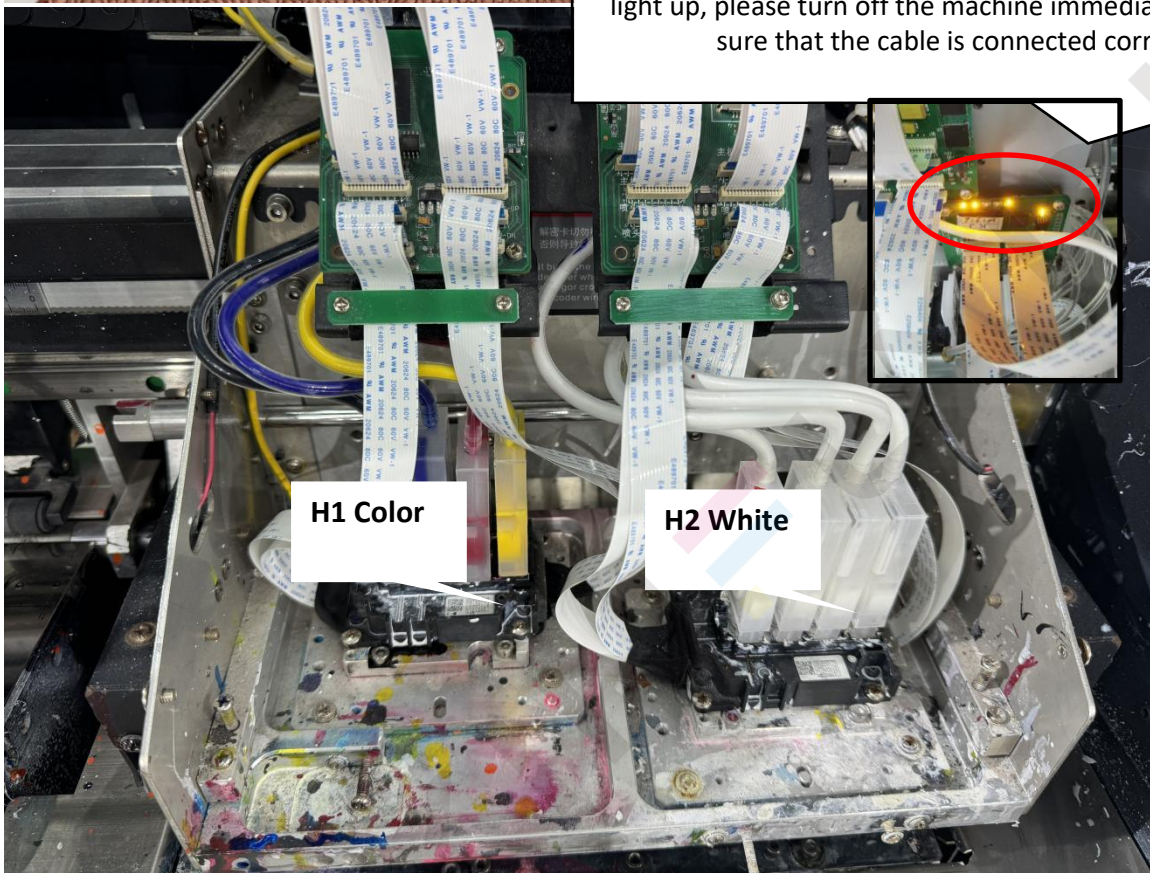

Notice:

- ① The cables connection of the print head and decoder, the decoder and print head, these should be connected properly according to the marks on the decoder and head board. To avoid abnormal situation happen.
- ② When you connect the cables, need to note that the metal part of the cables whether plug well, NO bending.
- ③ The cables should be aligned well and plug in properly with appropriate force, not violent, crooked insertion, also do not insert reverse.

8.4 Damper Installation

Take out the damper. Install the color print head's dampers in the order of KCMY (black, cyan, magenta, and yellow); There is no specific order for the white ink dampers; After adding ink to the cartridge, use a syringe to remove any air bubbles and ensure that the ink flows smoothly into the damper and tube. Align and place well the dampers into the print head, and install it with appropriate force.

① **Shake evenly the ink bottle before pouring to prevent the ink sedimentation. Pour the ink into the corresponding ink cartridge.**

② **You can only hold the dampers on the sides because the middle of the dampers is very fragile.**

③ **When the dampers are installed and removed, it is best to put dust-free cloth or tissue on the both side of the print head to prevent ink from leakage, which will damage the print head and boards.**

④ **Turn the damper upside down and use a syringe holds against damper firmly to suck the ink out ; the ink in the damper should reach the position of the red line , and then put it back to the original position.**

⑤ **The damper should be installed in place to prevent ink leakage**



9. Power-on inspection

There is a wire with yellow and green color on the right corner of the printer, which should be connected the earth wire well. Besides the power supply cord, it is necessary to plug in the earth wire as well. If your printer does not connect to the earth wire, the boards and print heads will be damaged, If this is the reason for the damage to the boards and print heads, the printer's boards and print heads will not be covered under warranty.

Ensure a one-to-one connection between the print head, decoder, and head board. First, connect the decoder to the head board, and then connect the print head to the decoder. Place your hand on the Emergency Stop. Turn on the printer and observe for any abnormal situations, such as the LED18 on the head board flashing red light or the decoder not lighting up. If any of these issues occur, press the Emergency Stop button within 2 seconds to stop the printer. Then, check if the cables are connected in reverse or misaligned, and inspect if the metal part of the print head is bent or broken.

Decoder Diagram:

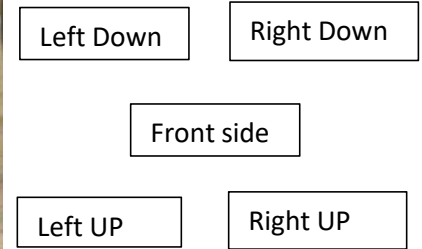
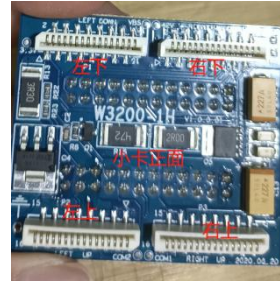
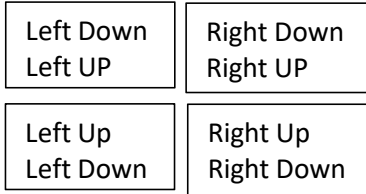

10. Debug Before Printing

10.1 Confirm ink stack and cleaning parameters

Open the software → Advanced Mode → Manufacturer mode → Enter password 111111 → Ink stack capping should be aligned well with the print head; Confirm the pumping height (moisturizing height is consistent with pumping height), The ink stack should be lowered 1mm where it fits into the print head; Confirm the position of the flash spray height, ink stack and print head place well; Confirm that the wiper is 0.2mm higher than the print head; Turn off the printer, then you manually push the carriage in a slow speed, observe whether the print head scratch on the film press clip, next adjust the height of the carriage, 0.2mm higher than the printing platform, observe whether the cables are pulled, need to sort out the cables.

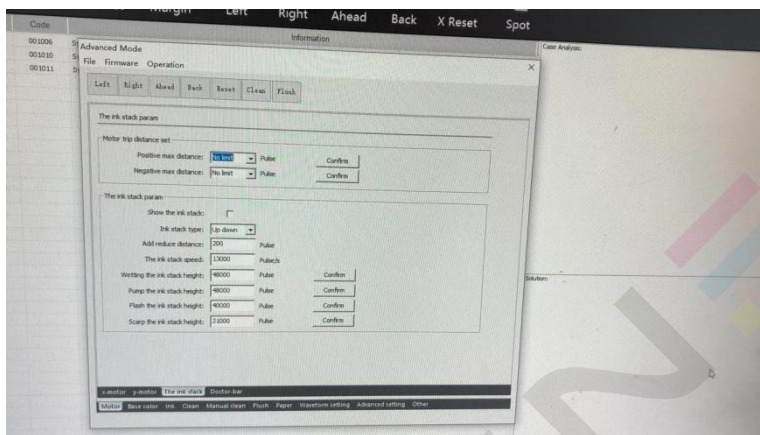

10.2 Print Nozzle Test & Confirm the status of Print Head

1. Print Nozzle Test

Connect the machine to the power supply and enter the printing software interface. (Note: the ink stack should be closed to the print head after the machine self-check is completed).

Load ink for 12 seconds and confirm that ink is flowing out of the waste ink tube, then stay still for 1-2 minutes, and then click the clean icon **“WEAK CLEAN”**. After the cleaning is complete, confirm that the platform is free of obstacles, then print a nozzle test. Then you observe the ink out of the print head, if there is no ink or ink missing on the test strip, **“WEAK CLEAN”** again. **If there is no improvement after cleaning for 2-3 times, Needs to contact**

our technicians.

If the ink performance is not good, the print head should be cleaned well, and then print again(Once printing, you need to make a nozzle test firstly as mentioned above)
IF DON'T KNOW HOW TO CLEAN, please contact our technicians.

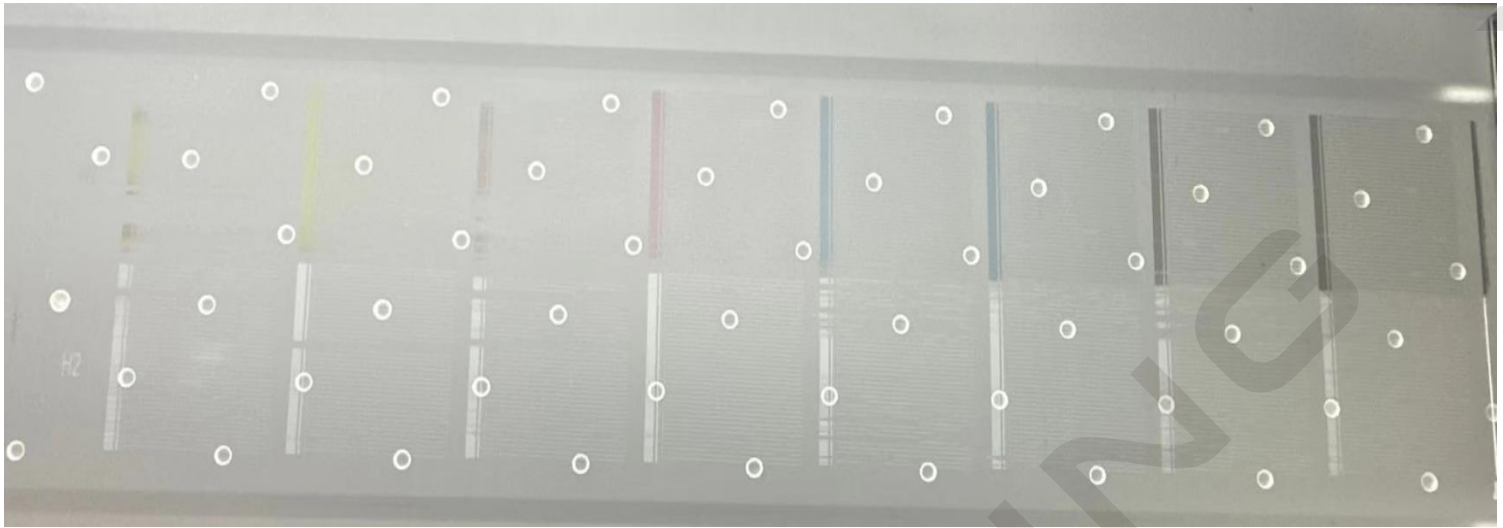
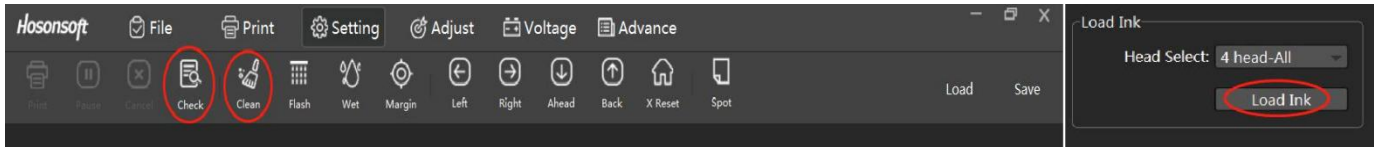

Test Strip with problem (ink not come out 100%, and all color not show in single line)

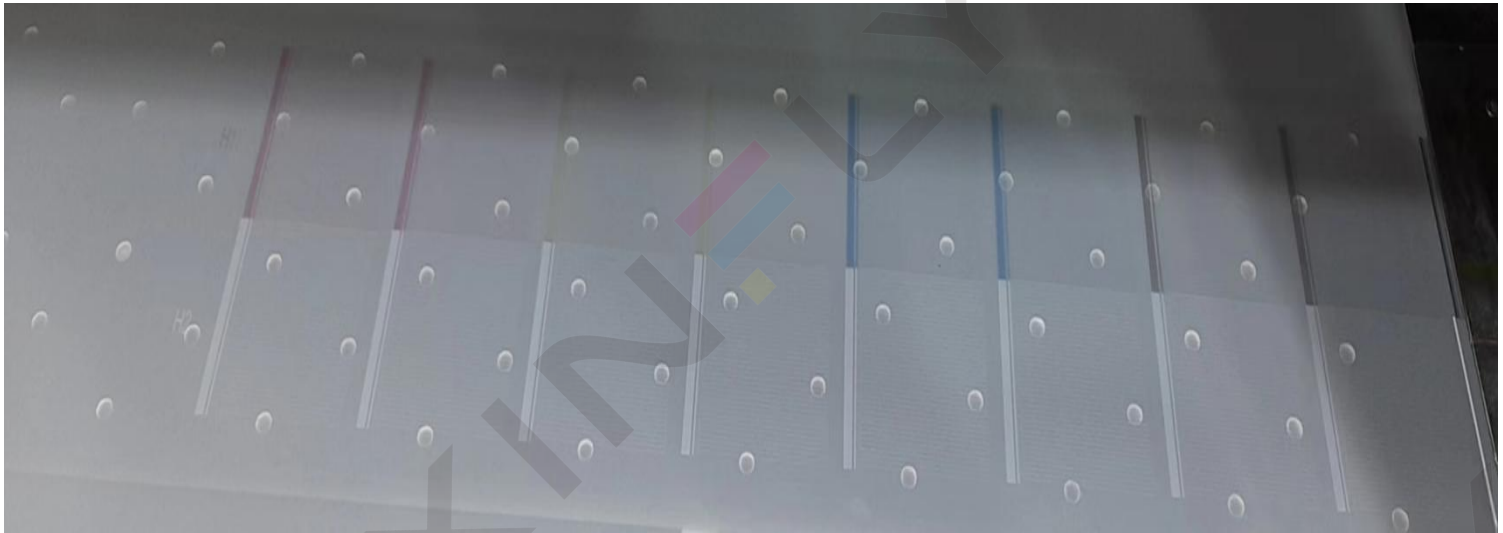

Normal Test Strip (all ink come out 100% and all color show in single line)

11. Alignment & Calibration

11.1 Vertical Alignment Of the Print Head

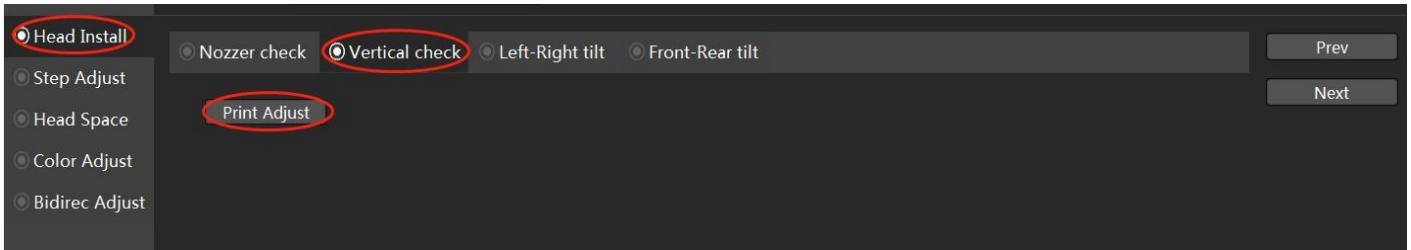

For vertical calibration, the vertical direction of the test chart required to be printed is a straight line. The vertical calibration chart below shows that the print head has been tilted and needs to be calibrated.

If there is a deviation, loosen the fixing screw of the print head and adjust the position of the print head. You can "push the print head up to the left". Then Print Adjust again, reach to form a line.

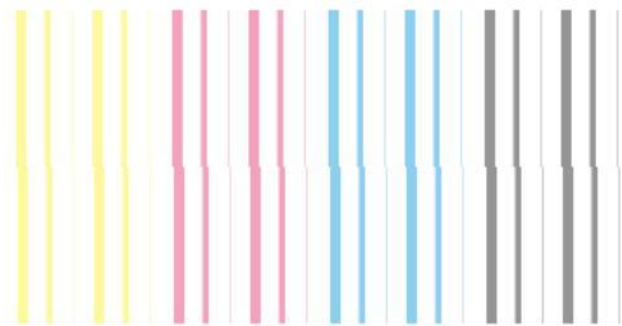

Enter the software option " Adjust" interface and align the print head vertically "Print Adjust".

11.2 Step calibration

Step calibration, Print Adjust.

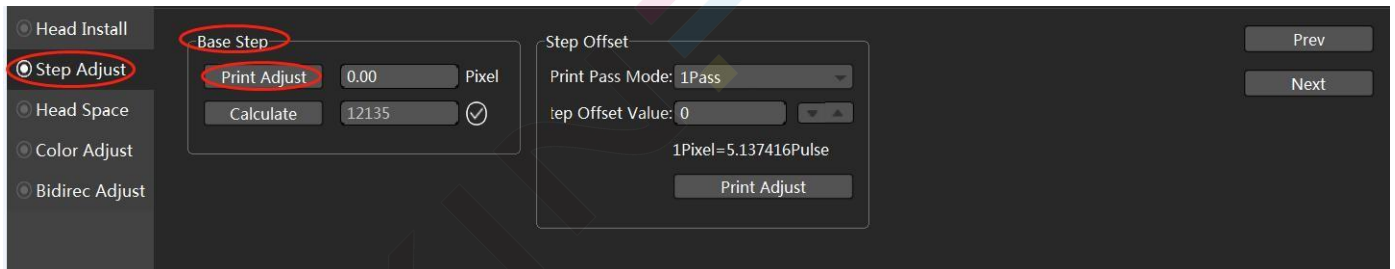

The calibration chart is at the value -2, and the lines completely overlap

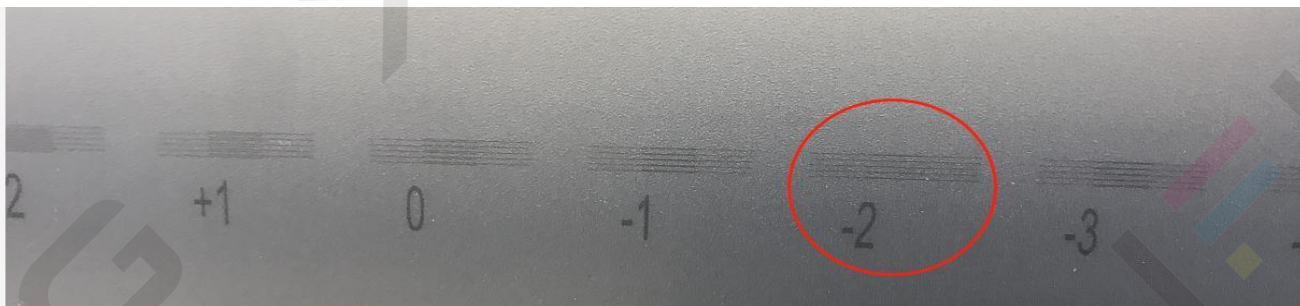

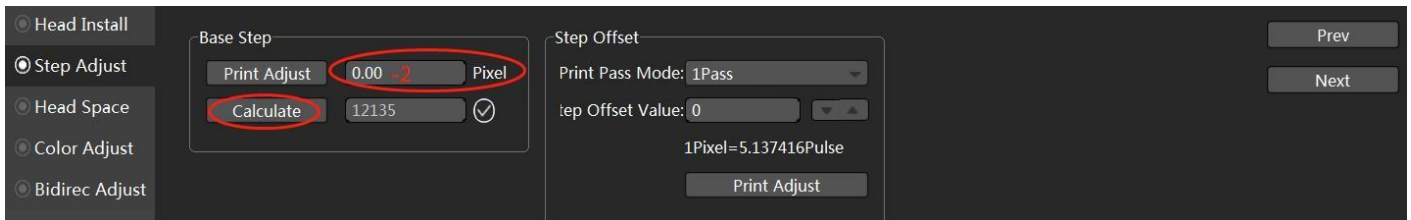

So enter the value -2 in the corresponding input box, and then click Calculate. Print Adjust again and confirm that the line at the value 0 is the most uniform. Need to click the "Save" button in the upper right corner.

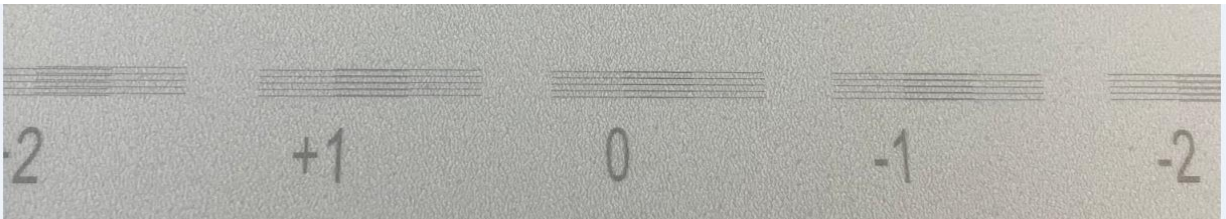

11.3 Calibration of nozzle horizontal space

Calibration of the horizontal distance between the print heads, Print Adjust.

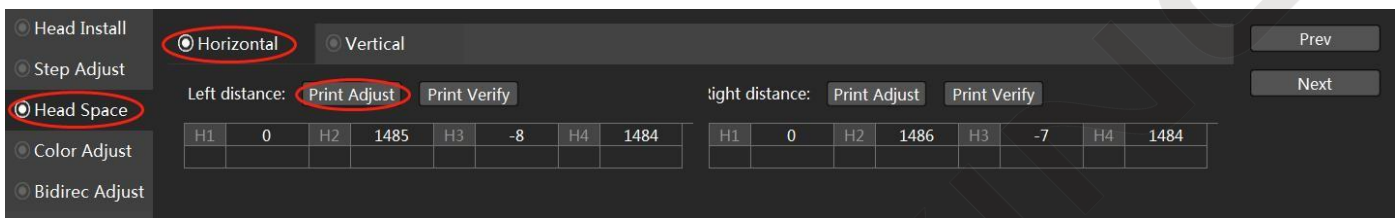

The calibration chart is at the value +2, and the lines completely overlap.

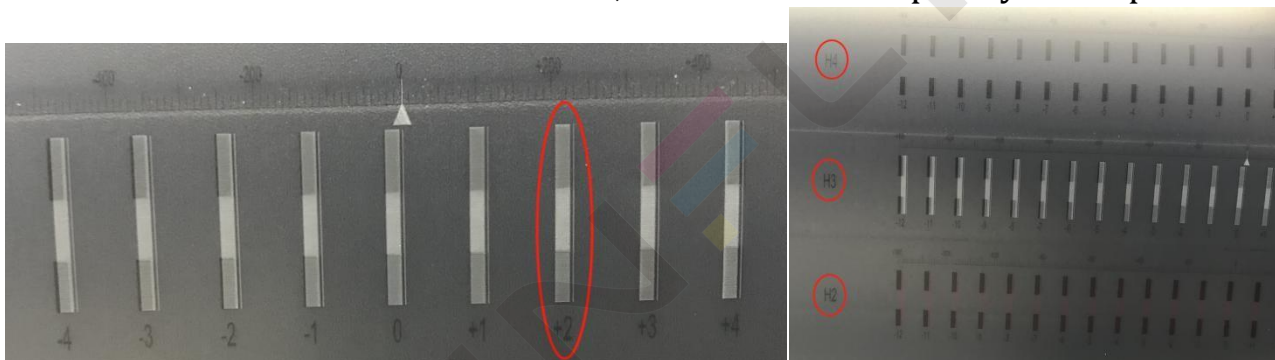

In the corresponding print head, increase or decrease the corresponding value in the input box of the corresponding printing direction.

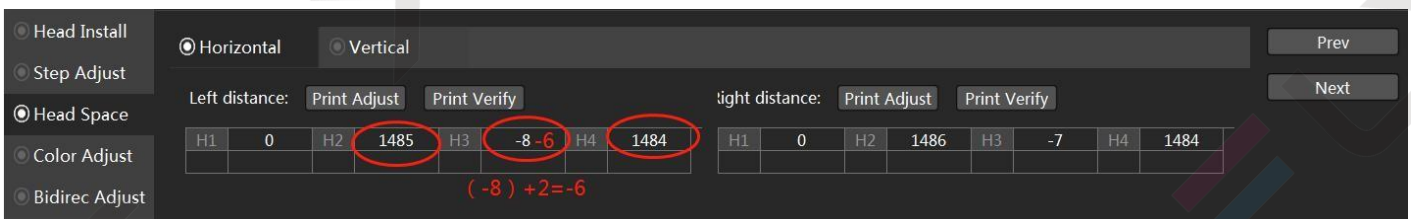

Print Adjust again and confirm that the line at the value 0 is the most uniform. Need to click the "Save" button in the upper right corner.

Then calibrate the direction to the right, the steps are the same as above.

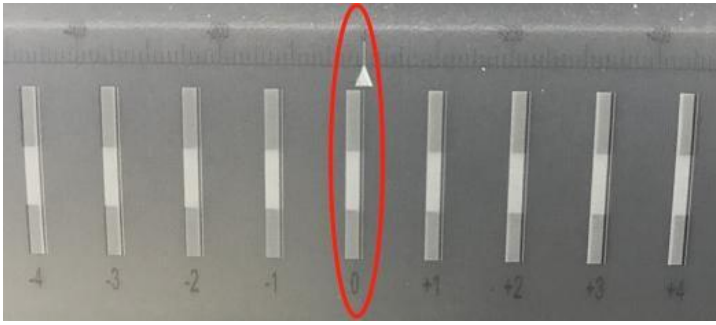

11.4 Nozzle vertical space calibration

Calibration of vertical spacing between nozzles. Print Adjust.

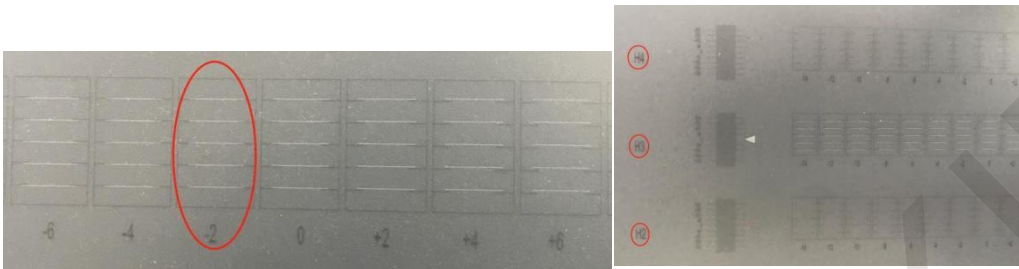

The calibration chart is at the value -2, and the lines completely overlap.

In the corresponding print head, increase or decrease the corresponding value in the input box of the corresponding printing direction.

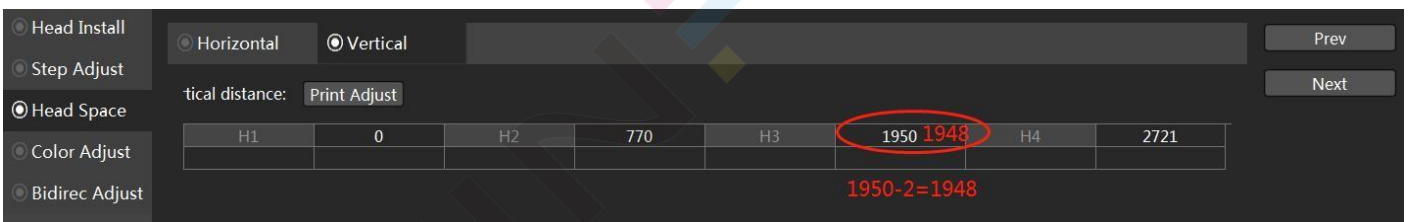

Print Adjust again and confirm that the line at the value 0 is the most uniform. Need to click the "Save" button in the upper right corner.

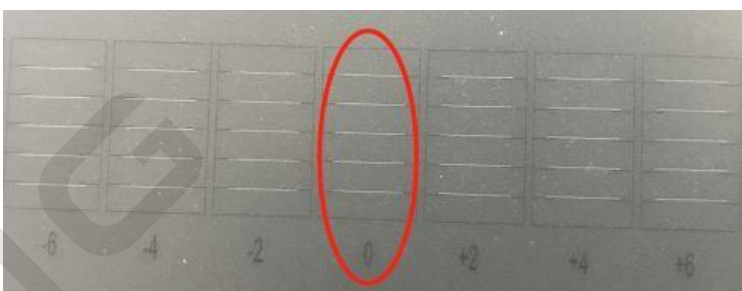

11.5 Bidirectional printing calibration

Finally, perform bidirectional printing calibration, Print Adjust.

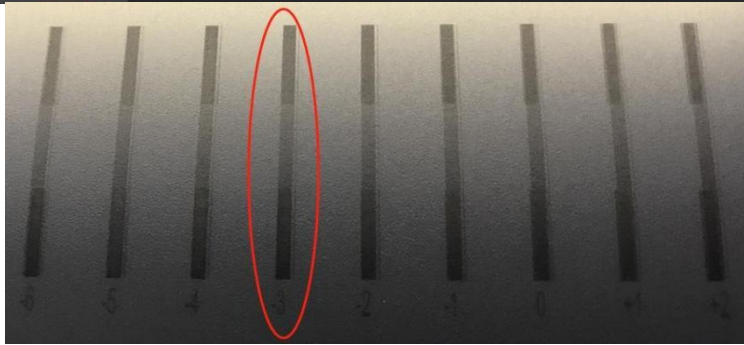
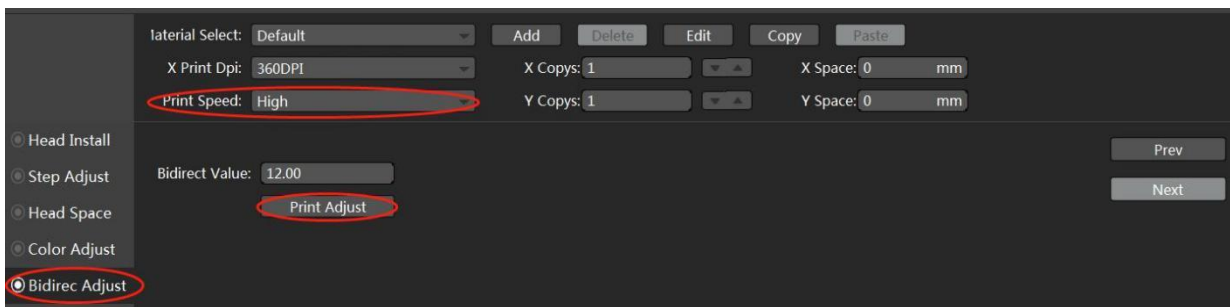

The calibration chart is at the value -3, and the lines completely overlap.

Select the corresponding printing speed, and increase or decrease the corresponding value according to the calibration chart.

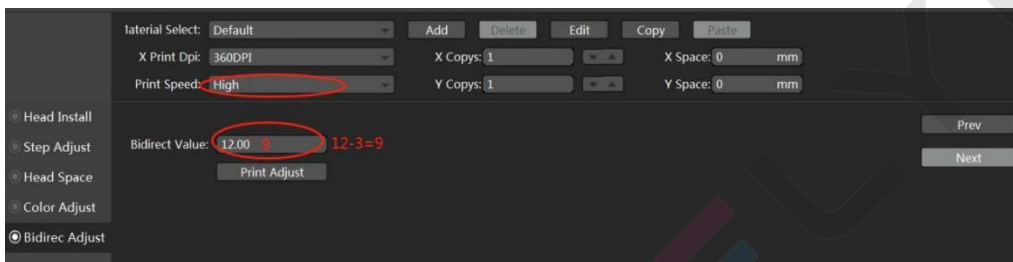

Print Adjust again and confirm that the line at the value 0 is the most uniform. Need to click the "Save" button in the upper right corner.

Finally, switch to different speeds to calibrate the two-way printing values and save them separately.

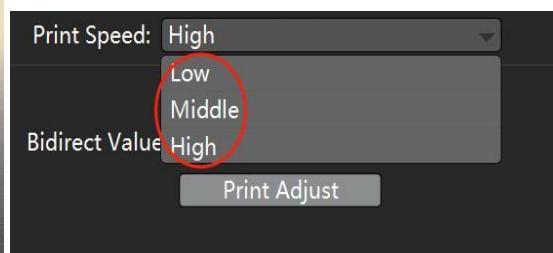
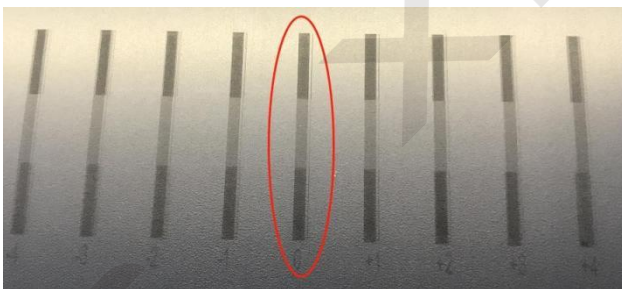

Background factory settings

Password:

Generally model:111111

Factory model: Ctrl+F12 into factory model,then enter password:222222

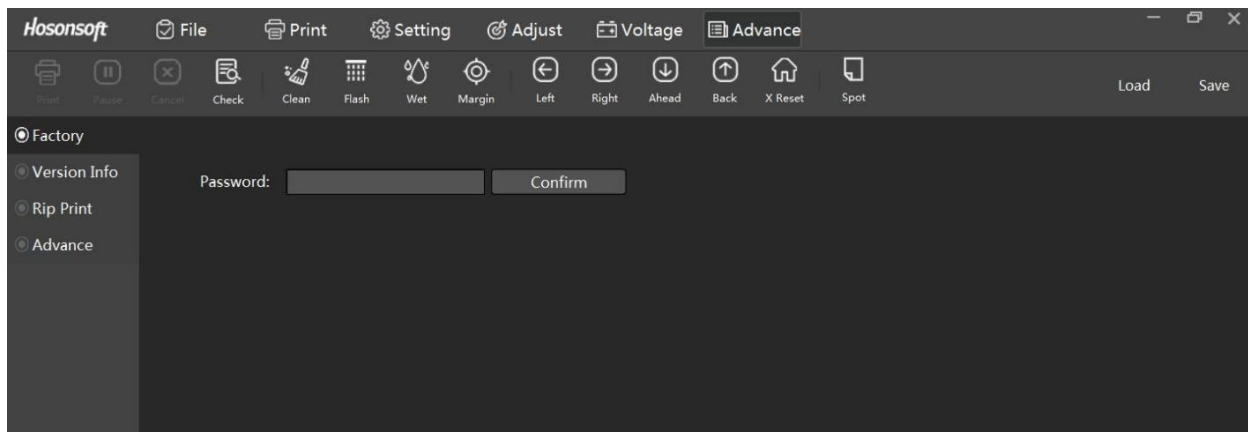

Version information

Click the version information in the advanced interface and enter the following interface:

Change key panel language

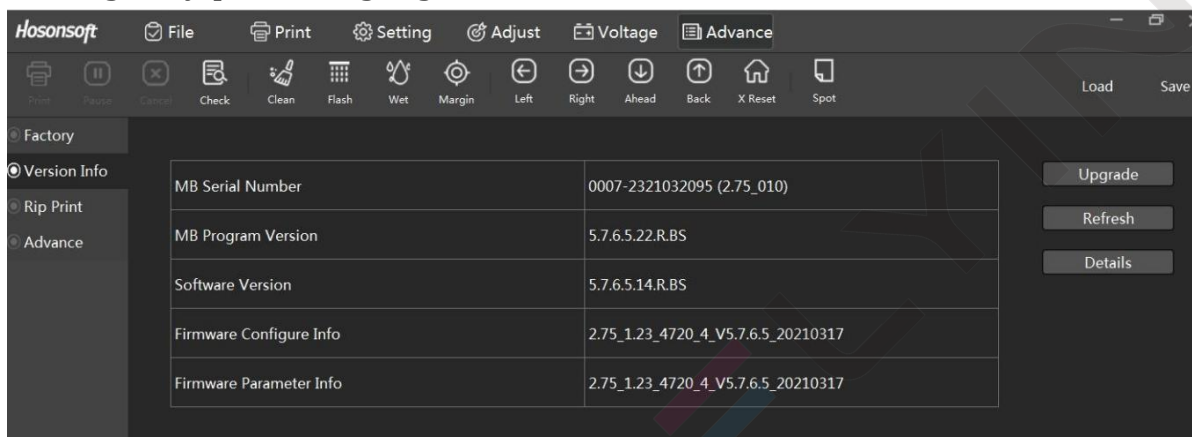

Select advance-encryption-language.as shown below

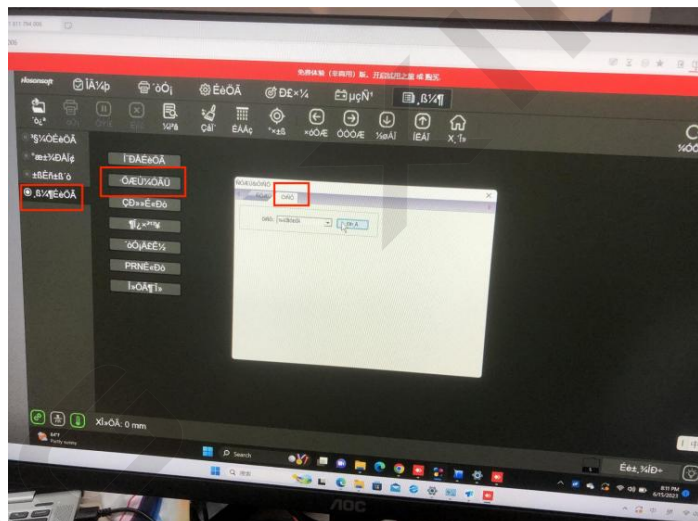

12. Optional Device

1. **Automatic moisturizing system:** Automatic moisturizing print head, prevent clogging

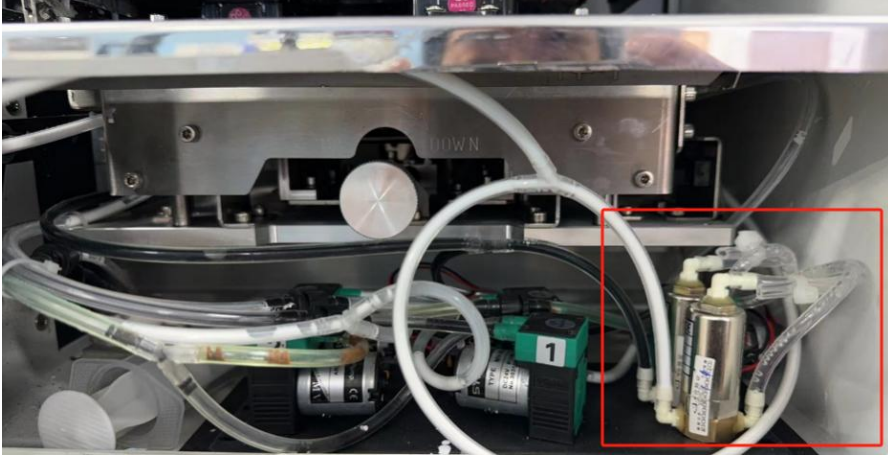

2. **Automatic paper feeding system:** It makes the printing film move forward more stable, and prevent the printing accuracy changes.

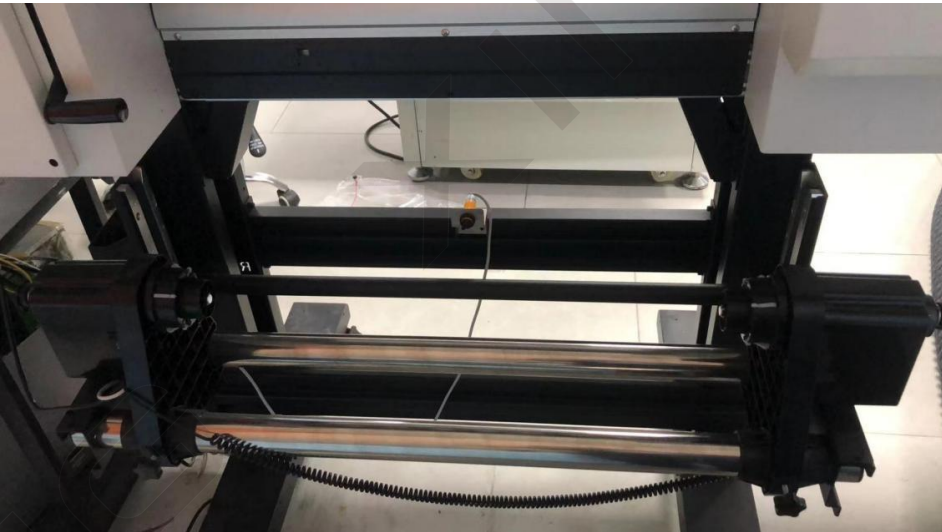

13. Precautions & Maintenance

Precautions for printing equipment

In order to ensure the good operation and extend the lifespan of the printer, it is essential to ensure that the printer is operated in an environment that strictly conforms to the standards. The following requirements are needed for the machine environment:

- (1) The printing room's temperature must be between 20°C - 35°C (68°F - 95°F), humidity ranges from 35% to 70%RH
- (2) The machine must be equipped with a voltage regulator or UPS (voltage fluctuation range should not exceed $\pm 5V$), which should be connected to the earth wire.

Maintenance of The Printer(According to our maintenance manual)

- (1) Check the status of the print head when starting up and shutting down the machine.
- (2) Close the software before shutting down and check whether the carriage is reset well.
- (3) Follow the maintenance manual we sent to perform daily maintenance on the printer.
- (4) Keep a distance of 10cm between the printer and the powder shaker.
- (5) Do not touch the heated printer platform.

Regarding holiday maintenance for the printer:

I believe that friends who use printers will be concerned about how to maintain the machine during holidays and ensure that the equipment can function properly after the holidays.

Check whether the print head is normal, print the nozzle test strip, if there is ink missing(The ink came out that is not good, the nozzle test is not complete), it is need to Weak Clean first to ensure that the nozzle test is complete.

Check the print head to ensure it is in good condition, and then follow these steps:

Method Without Moisturizer: (Simple operation, but there is a certain risk of print head clogging if the machine is not used for a long time)

- (1) The print head should be soaked in pure water, if you do not know how to soak, please contact us for the video.
- (2) The print head must be sealed and moisturized.It means that the print head must be aligned and closed with the ink pad to seal and moisturize the print head. Otherwise, the print head will be clogged.
- (3) Use ink tube clips to clamp all ink tubes.
- (4) Tighten all ink cartridge cover.
- (5) Clean up the waste ink.
- (6) Seal the hot melt powder and printing film to prevent moisture.

(7) DO NOT let your printer and shaker with dust, please take good measures to prevent dust from the machine.

Method With Moisturizer: (Complicated operation, but it can reduce the risk of print head clogging if the machine is not used for a long time)

(1) Pour the remaining ink into a clean and empty cartridge to prevent ink precipitation.

Advice: It is best to use up the ink in the ink tank on the printer in advance..

(2) Clean the ink tubes and dampers. Firstly, take out the damper, use a syringe to draw out the ink in the dampers and ink tubes, then rinse the ink cartridges and ink tubes with pure water/distilled water. (And we will send the video to you, for showing how to clean, just watch the front part)!!

(3) Use a syringe with small hose to flush the print head with pure water. Make sure there is no ink inside the print head. Then use a syringe with sleeve hose to slowly inject the moisturizer into each channel of the print head. The force should not be too strong. (During the operation, place tissue or dust-free cloth on both sides of the print head to prevent liquid from flowing into contact with the head and cables, because it will burn the heads)

(4) Tighten all ink cartridge cover.

(5) Clean up the waste ink.

(6) Seal the hot melt powder and printing film to prevent moisture.

(8) DO NOT let your printer and shaker with dust, please take good measures to prevent dust from the machine.

Reminder:

If the machine encounters any malfunctions, please contact a technician for assistance with repairs. Incorrect operation may cause significant damage to the printer.

E602 软件安装

This machine is connected by a network cable, and the IP address of the computer needs to be fixed first

Open the computer settings to find the network option

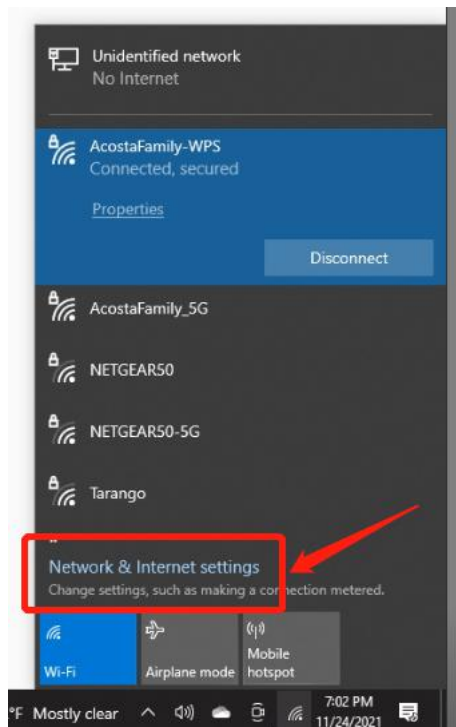

Open the change adapter option

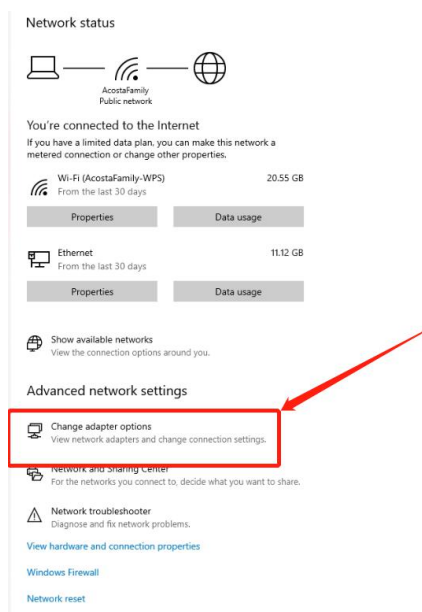

Find your network port, Double-click to open and find the properties

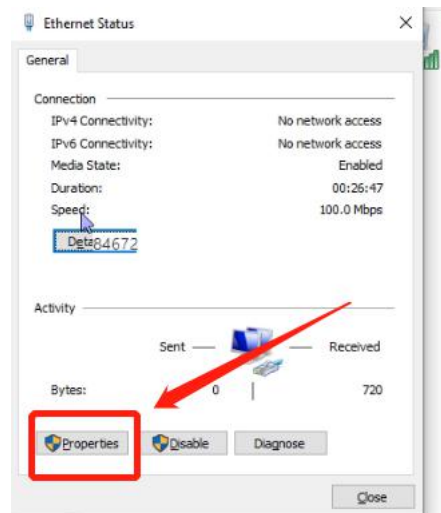
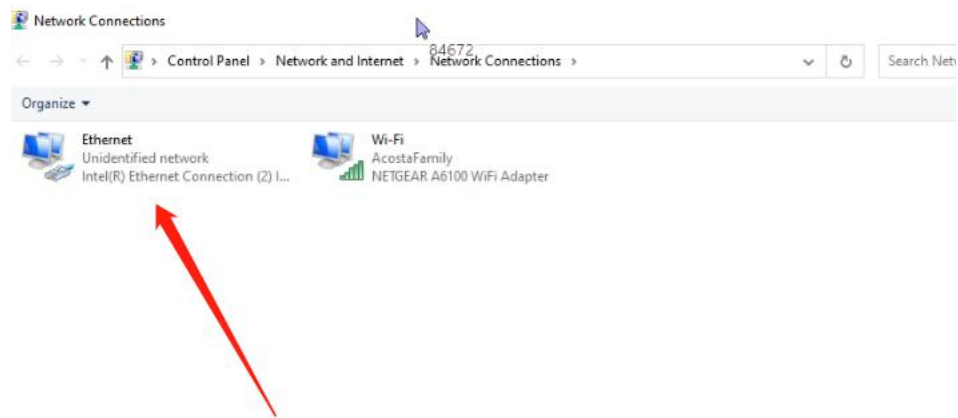

Choose Internet Protocol version 4 (TCP/IPv4) ,Properties

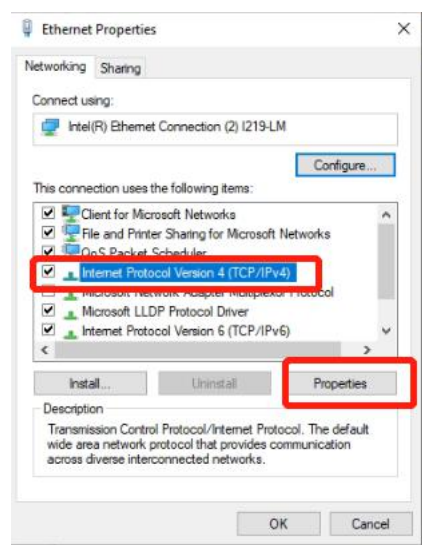

Set to be the same as the picture

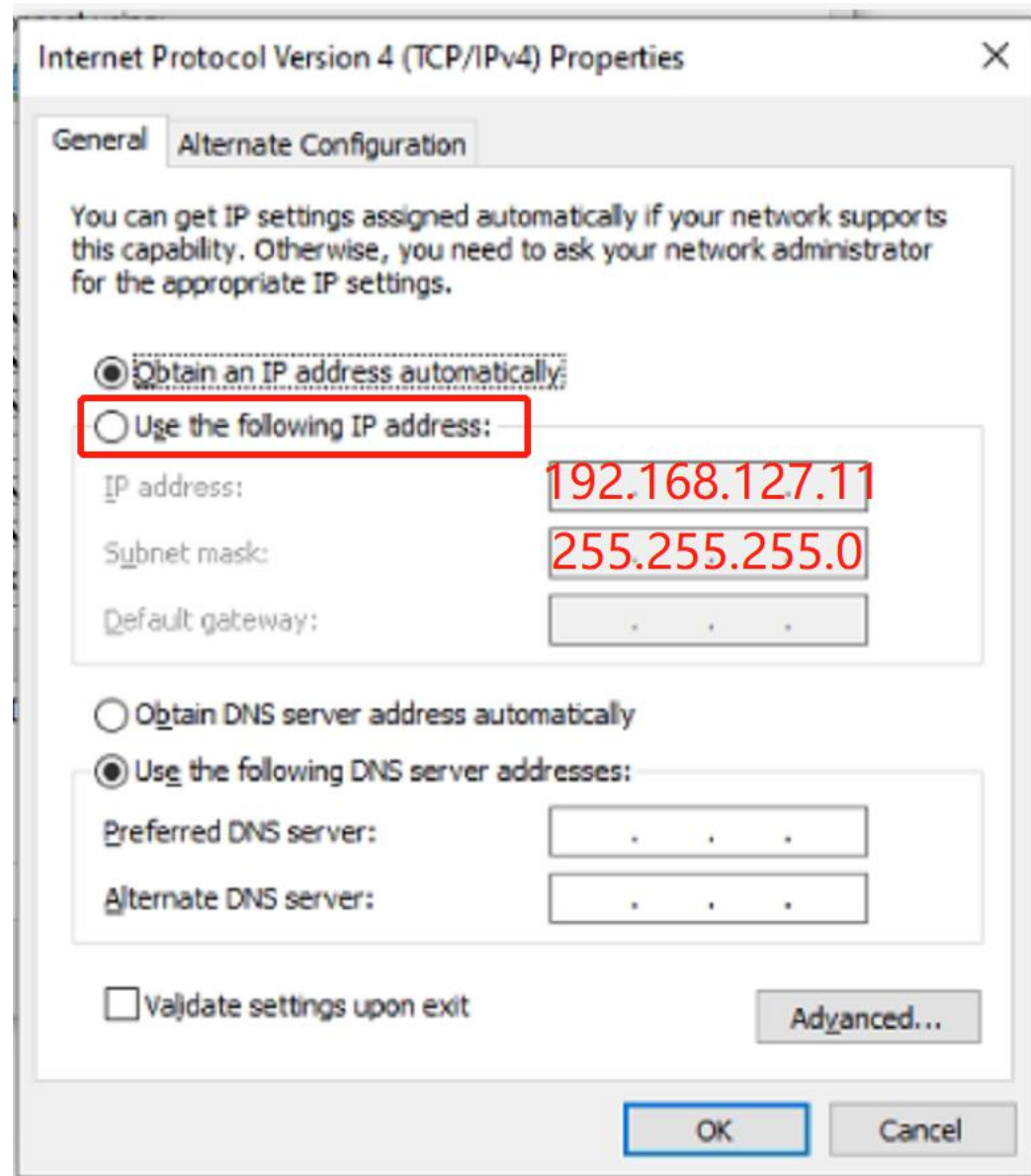

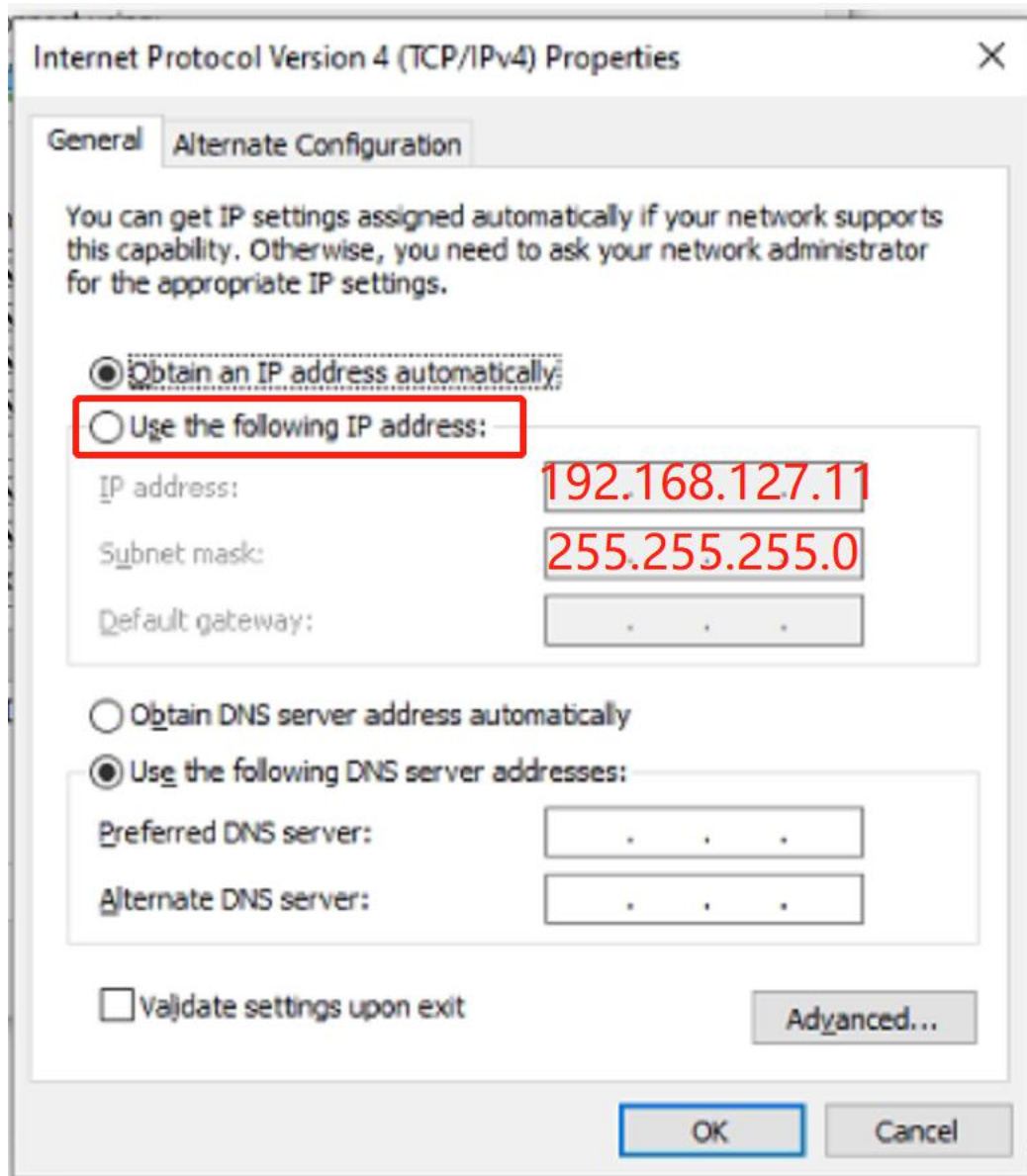

Click OK to complete

Unzip the received file

E602	2021/9/19 下午 03:19
E602.zip	2021/9/19 下午 03:19













Open the control software folder

名称	修改日期
controlling software	2021/5/31 下午 07:00
ICC	2021/5/31 下午 07:01
Modify vertical-20210528	2021/9/19 下午 03:17
Motherboard program	2021/9/19 下午 03:18

Unzip the compressed package inside

 PrintExp_V5.7.6.1.69.BS	2020/11/12 下午 07:56
 PrintExp_V5.7.6.1.69.BS.rar	2020/11/12 下午 07:58

Find Printexp, it is your control software, you can create a desktop shortcut

名称	修改日期	类型	大小
 HardDataIII.dll	2020/1/12 上午 11:55	应用程序扩展	23 KB
 hs_usb3.dll	2020/1/2 下午 09:40	应用程序扩展	51 KB
 IDCcreator.dll	2019/10/29 上午 10:24	应用程序扩展	17 KB
 ImgLoader.dll	2020/2/3 上午 11:45	应用程序扩展	43 KB
 InkCalMgr.dll	2020/1/4 下午 02:50	应用程序扩展	41 KB
 InkCalProc.dll	2020/1/9 上午 11:54	应用程序扩展	13 KB
 kftfityp.id	2019/10/11 下午 02:28	ID 文件	27 KB
 kthdbrd.id	2019/10/11 下午 02:28	ID 文件	5 KB
 ktmchtp.id	2019/10/11 下午 02:28	ID 文件	3 KB
 LogMgr.dll	2020/1/2 下午 09:40	应用程序扩展	51 KB
 mfc100.dll	2016/8/3 下午 02:55	应用程序扩展	4,241 KB
 msvcp100.dll	2016/8/3 下午 02:55	应用程序扩展	412 KB
 msvcr100.dll	2016/8/3 下午 02:55	应用程序扩展	753 KB
 NozzleClose.dll	2020/1/9 上午 11:54	应用程序扩展	62 KB
 NWReceive.exe	2020/1/2 下午 09:40	应用程序	74 KB
 NWReceiveProc.dll	2020/1/2 下午 09:40	应用程序扩展	14 KB
 PassDataProc.dll	2020/5/8 下午 08:22	应用程序扩展	54 KB
 PrintExp.exe	2020/5/11 下午 02:43	应用程序	1,110 KB
 PrintExp	文件说明: Hosonsoft-PrintExp 公司: Shenzhen HosonSoft Co., Ltd. 文件版本: 1.0.0.1 创建日期: 2021/9/19 下午 06:02	上午 09:29 下午 04:32 下午 08:22	Internet 快捷方式 1 KB 104 KB 62 KB
 PrintExpStyle.dll		应用程序扩展	
 PrintModule.dll		应用程序扩展	

打印头保养手册

Print head maintenance manual

1、在打印之前，需要用压纸片压住打印膜，把吸风开到 75，防止打印膜凸起来刚蹭到打印头。

1. Before printing, it is necessary to press the printing film with the Press clip and turn on the Vacuum to 75 to prevent the printing film from protruding and rubbing the print head.



2、打印必须要打开彩条。

2. printing must open the color bar.

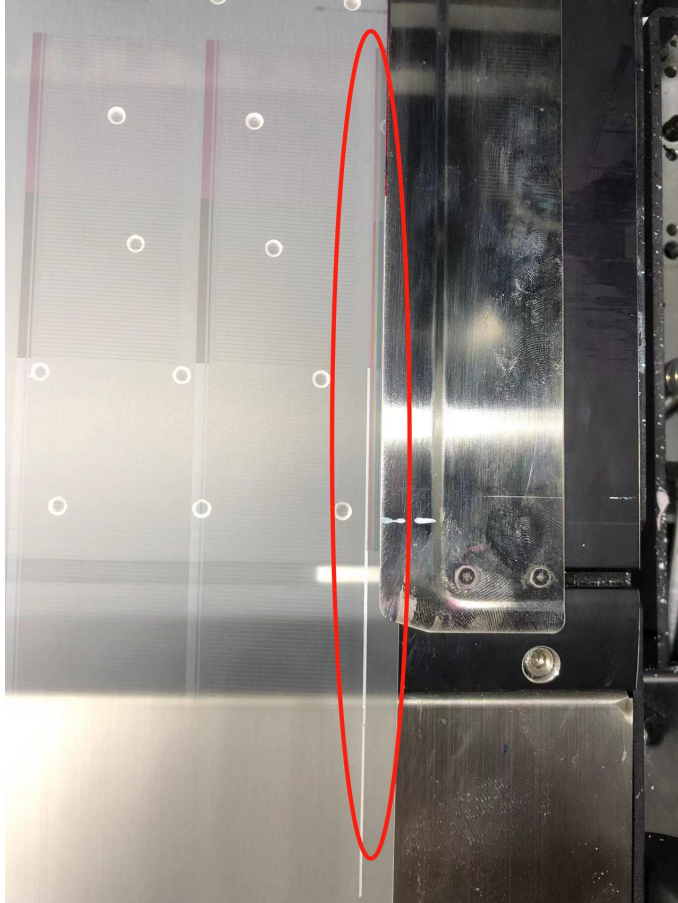

3、在打印中如果发现打印出来的图案有线条，需要暂停打印，打印测试条查看打印头状态是否完好。如果测试条有断墨，需要先清洗，打印出完整的测试条后才能继续打印任务。

3. During the printing, if the printed pattern is found to have lines, it is necessary to stop the printing and print the Head test to check whether the test has broken nozzle. If yes, clean it first and print the complete head test before proceeding with the printing task.

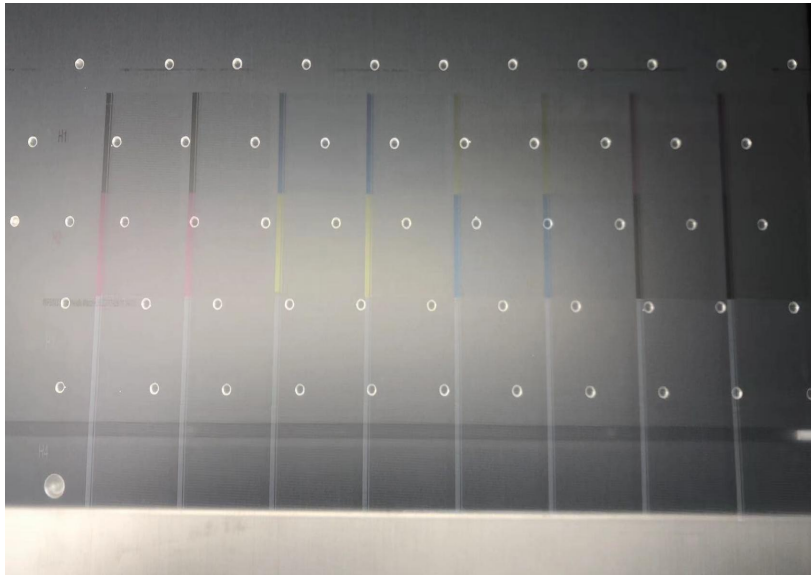

4、打印头的温度不能低于 20℃，不能超过 30℃，打印时室内温度保持在 20-30℃ 以内，湿度在 40%-60% 左右。如果在打印前，温度太低，就先使用温水浸泡着打印头，待打印头温度在要求范围内以后再开始打印。

4. The temperature of the print head should not be lower than 20℃ or more than 30℃. The indoor temperature should be kept at 20-30℃ and the humidity at 40%-60% when printing. If the temperature is too low before printing, soak the print head with warm water first, and then start printing when the temperature of the print head is within the required range.

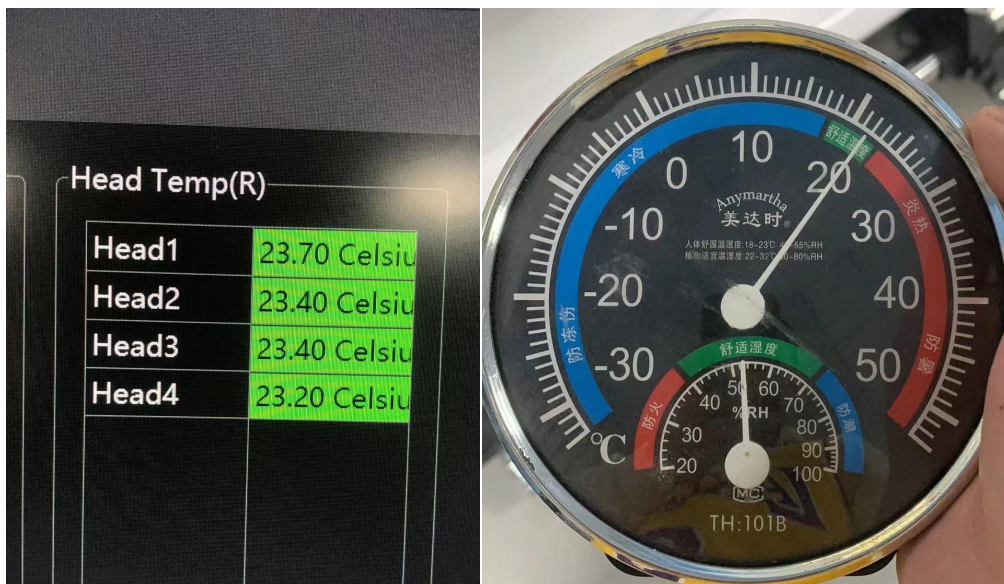

5、在关机前，需要再打印测试条查看喷头状态是否完好，要打印出完整的测试条后才可以

关机。

5. Before shutting down the printer, it is necessary to print the head test again to check whether the print head is in good condition. It can be shut down only after printing the complete head test

6、如果超过两天不使用打印机，需要使用纯净水浸泡着打印头，把墨盒端的墨管用夹子夹紧。

6.If you do not use the printer for more than two days, you need to clamp the ink tube tightly with a clamp, and then soak the print head with purified water.

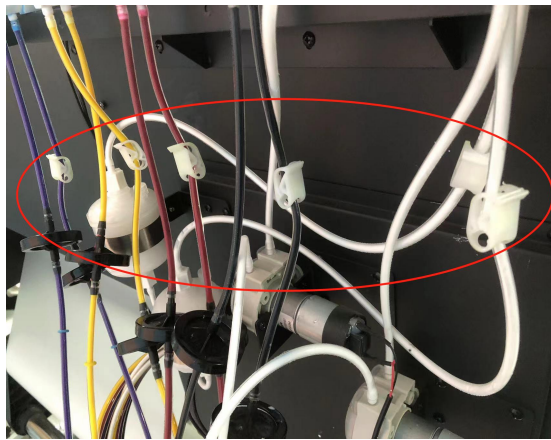

7、白墨循环需要每隔两天打开一次，开机后打开循环到 70，五分钟后开到 30，持续 10 分钟。完成后关闭白墨循环，清洗，然后打印测试条查看打印头状态

7. The white ink cycle needs to be turned on once every two days, turn the cycle to 70 for 5 minutes after machine on, then turn the cycle to 30 after five minutes for 10 minutes, after completion, turn off the white ink cycle, cleaning, and then print the test strip to check the print head status.

白墨循环
white Ink Cycle



打印机保养手册

Printer Maintenance Manual

一、刮片、墨垫、墨垫平台、压纸片、打印平台、小车底板每天下班前使用无尘布清理干净；

1. Wiper, Ink Capping, Ink capping station, Press clip, printing platform and Carriage bottom should be cleaned with dust-free cloth every day before leaving work;

刮片

Wiper



清理前

清理后

before cleaning

after cleaning

墨垫（红圈）和墨垫平台（黑圈）

Ink capping (red circle) and ink capping station (black circle)

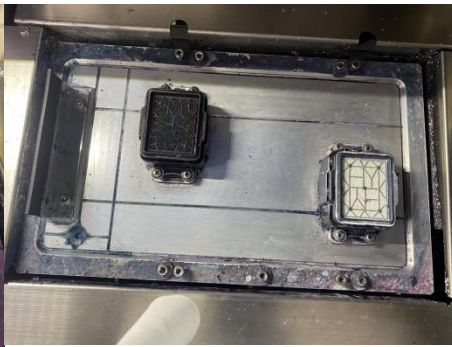
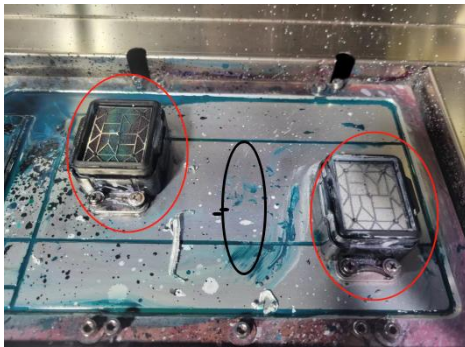

清理前

清理后

before cleaning

after cleaning

压纸片

Press clip

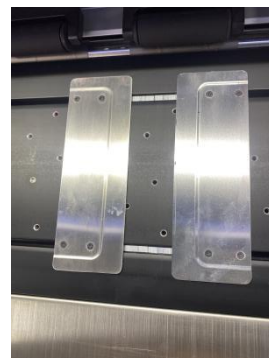
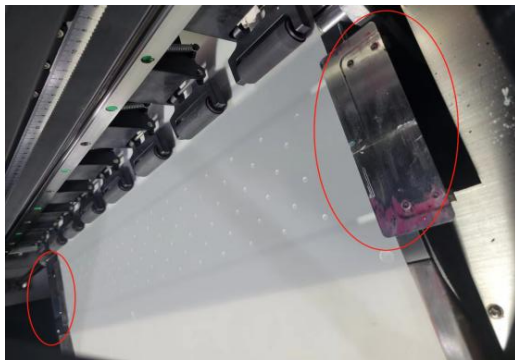

清理前

清理后

before cleaning

after cleaning

打印平台
Printing platform



清理前
before cleaning

清理后
after cleaning

小车底座
Carriage bottom

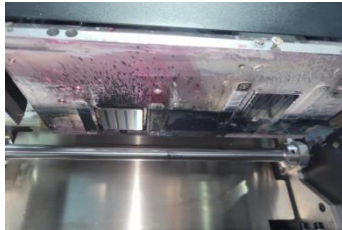

清理前
before cleaning

清理后
after cleaning

PS: 清理小车底座和喷头表面需要先把机器关机, 然后按照 P1 图中黄色箭头的方向旋转红色圈圈中的旋钮, 降低平台的高度, 然后手动把小车推到 P2 图中的位置。

PS: It will need to turn off the machine firstly before cleaning the bottom of the trolley and the surface of the printheads, then turn the knob in the red circle in the direction of the yellow arrow in the P1 picture to lower the height of the platform, and then manually push the trolley to the position in the P2 picture.

P1



P2

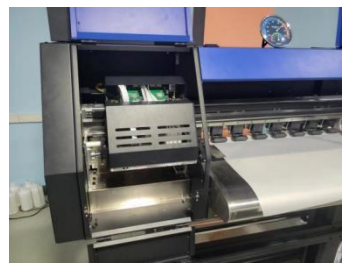

二、喷头表面 3 天清理一次, 用无尘布沾点蓝药水从上往下擦;

2. Please clean the printheads surface every three days, and wipe from top to bottom with a dust-free cloth which is dipped with blue cleaning solution;

喷头表面
Print head surface

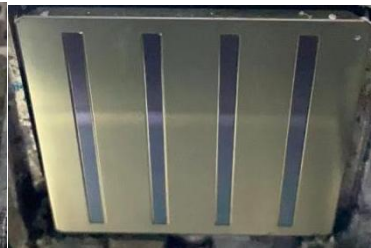

清理前
before cleaning

清理后
after cleaning

蓝药水
Blue head cleaning solution



无尘布
dust-free cloth



三、光栅条三个星期用无尘布粘点酒精擦一次，导轨一个月加一次缝纫机油；
3. The grating strip is wiped with a dust-free cloth with a little alcohol once every three weeks, and the guide rail is added with sewing-machine oil once a month;

光栅条
Grating strip

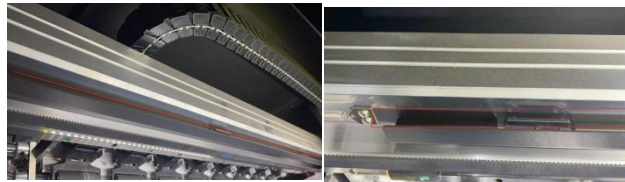

导轨
Guide rail

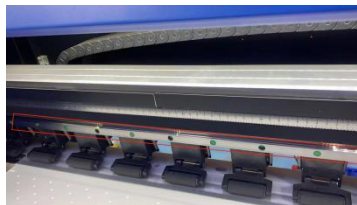

四、打印中要加彩条，防止打印中堵头；
4. Add color bar during printing to prevent heads from clogging;



五、打印前先打个测试条，确认没断墨再打印（出现断墨就要清洗好再打印）；
5. Print the nozzle test before production to make sure the situation of heads. (If the nozzle test is not good, clean it to good ,then start production);



测试条断墨

Test Strip with problem (ink not come out 100%, and all color not show in single line)

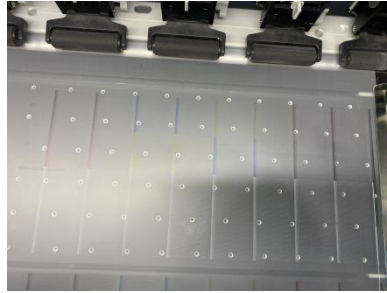

正常的测试条

Normal Test Strip (all ink come out 100% and all color show in singel line)

六、打印过程出现断墨（图案有线条），需要暂停并且清洗；

6. During printing ,if there is ink cut off (The pattern with lines) ,then you should stop printing and do cleaning for printer heads ;



红色断墨

Red -ink cut off



白色断墨

White-ink cut off



清洗

Cleaning

七、每天关机前也需要打个测试条（正常测试条看保养第五条），断墨要清洗好再关机；

7. Please print test strip after you finish your production everyday (see 5th # maintenance books # for the normal test strip), and the machine should be cleaning before shut down;

八、机器超过两天不用需要用纯净水浸泡打印头（浸泡打印头详情看另外发送的视频），墨管夹好防止虹吸漏墨；

8.Once the printer no need working for more than 2 days ,we advice that you should soak the print head with pure water (see the video of how to soak the print head), and the ink pipe need be clamped to prevent siphon ink leakage;

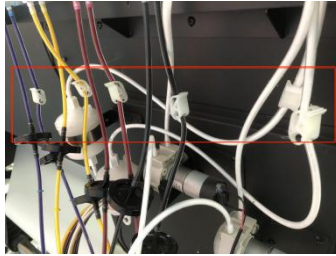

九、如果三天以上没有使用机器，要开白墨循环 60-70，循环 15 分钟后关闭循环，静止 10 分钟，然后喷头注墨 15 秒再清洗，最后打测试条检查打印头状态；

9. One the printer no need working for more than 3 days, before you do printing , please turn on the white ink circulation system 60-70, make it working 15 minutes then turn off , and waiting 10 minutes , then inject ink into the nozzle for 15 seconds before cleaning, and finally print a test strip to check the print head status;

白墨循环旋钮

The white ink cycle button



十、打印环境保持温度 20-30，湿度 40-60。

10. The room environment request 20-30 degrees centigrade and 40 - 60% humidity.



注意事项:

Notes:

一、打印过程不要触碰打印膜，以免打印膜刮伤喷头；

1. Do not touch the printing film during printing to avoid the printing film scratching the nozzle;

二、加墨水前要用力摇晃墨水瓶子防止沉淀；

2. Before adding ink, shake the ink bottle vigorously to prevent sedimentation;

三、打印膜和热熔粉保持干燥不能受潮，热熔粉超过 3 天不使用需要用密封袋密封，打印膜超过 3 天不使用需要使用保鲜膜包好；

3. The printing film and hot melt powder should be kept dry and free from moisture. If the hot melt powder is not used for more than 3 days, it shall be sealed with a sealing bag. If the printing film is not used for more than 3 days, it shall be wrapped with a fresh-keeping film;

四、膜从抖粉机出来前要盯一下，以免膜变形不出来顶在抖粉机内部；

4. Keep your eyes on the film before it comes out of the shaker, avoid it can not comes out due

to deformation and keep inside the shaker;



五、抖粉机每天下班要清理干净机身上面的粉(除了粉槽和底下抽屉);

5. The powder on the shaker body should be cleaned every day, except for powder tank and the bottom drawer;

六、打印中突然停电, 需要手动把小车推回原位喷头复位保湿好。

6. power cut during printing, the carriage need to be push to origin and keep the print head wet.



小车复位原点

carriage reset origin

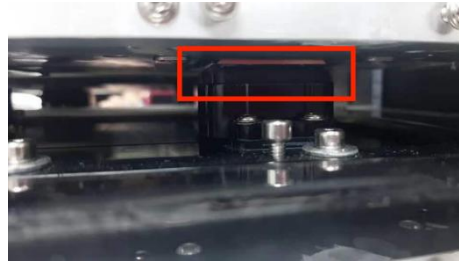

打印头表面和墨垫密封保湿

carriage resets the origin print head surface and ink cap to seal and moisturize

打印机需要定期更换和清洗的配件:

Accessories that need to be replaced and cleaned regularly:

1. 墨囊、彩墨过滤器每半年更换一次, 白墨过滤器每三个月更换一次;

1. Replace the ink damper and color ink filter every six months, and replace the white ink filter every three months;



墨囊

ink damper

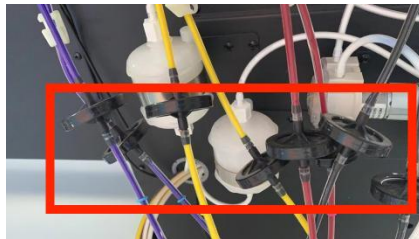

彩墨过滤器

Color ink filter



白墨过滤器

White ink filter

2. 刮片 (图片在保养第一条)、墨垫 (图片在保养第一条)、墨泵每半年到一年更换一次;

2. The press clip (the picture is in the first item of maintenance), ink cap (the picture is in the first item of maintenance) and ink pump should be replaced every six months to one year;



墨泵

Ink pump

3. 墨盒、墨管每年需要使用纯净水清洗一次，或者超过一个月没使用机器也需要清洗；
 3.The ink cartridge and ink lines need to be cleaned with purified water once a year, or the machine has not been used for more than a month;



墨盒

Ink cartridge



墨管

Ink tube

4. 光栅条（图片在保养第三条），压纸轮，阻尼器，小车长皮带，减速皮带每一到两年更换一次（出现磨损需要更换）；

- 4.The grating strip (the picture is in the third item of maintenance), pinch roller, damper, carriage long belt, and deceleration belt should be replaced every one to two years (replacement is required in case of wear);

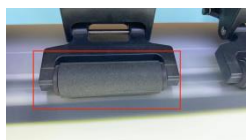

压纸轮

Paper pressing wheel

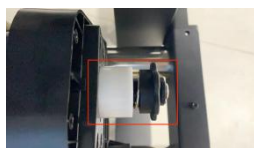

阻尼器

damper

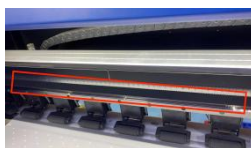

小车长皮带

Trolley long belt



减速皮带

Speed reduction belt

5. 其它配件出现损坏时更换。
 5. Replace other accessories when they are damaged.

Maintop installation

热转印打印机使用 6.0 白墨烫画使用 6.1，安装方式是一样的

The heat transfer printer uses 6.0 and the white ink hot stamping uses

6.1. The installation method is the same

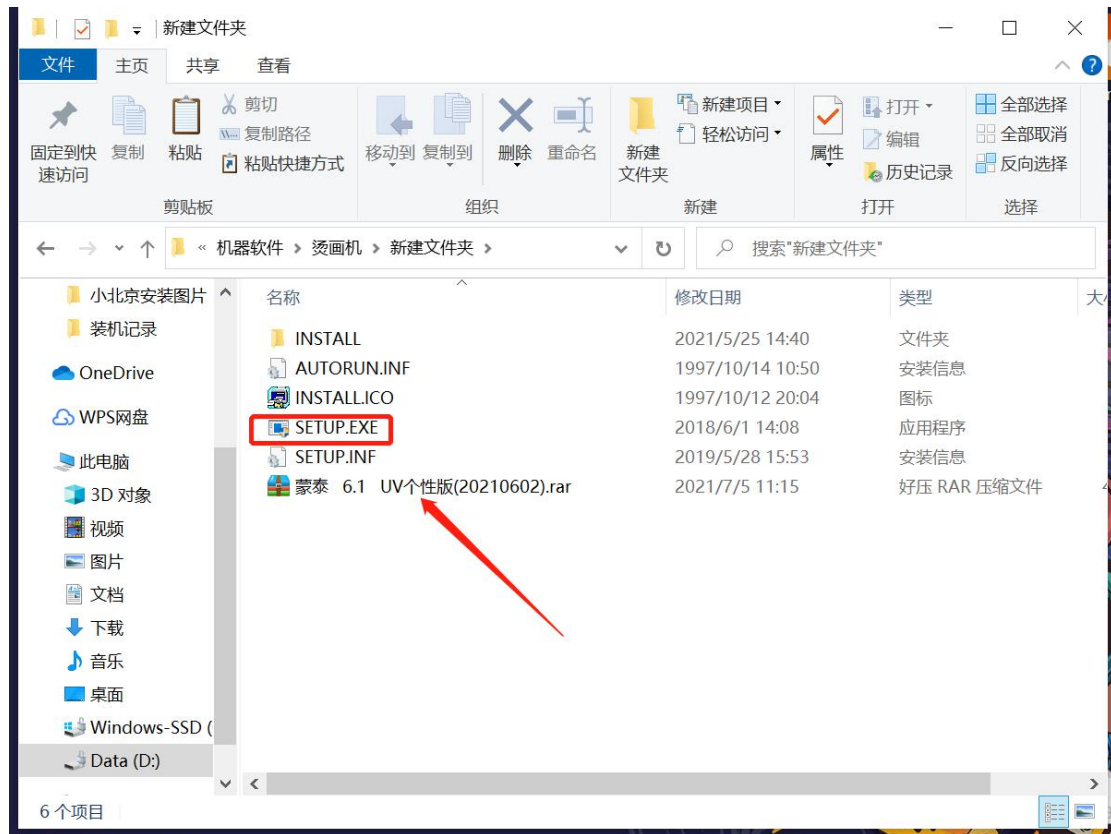

第一步解压发送的压缩包，如果电脑有光驱可以直接用盒子里的光盘
打开

The first step is to unpack the sent packet. If the computer has a

CD-ROM drive, it can be opened directly with the CD-ROM in the box



SETIP.EXE

里面还有解密钥匙

It also contains the key to decryption

安装 蒙泰彩色电子出版系统

选择安装语言
请选择要安装的语言:
英文
简体中文
英文



扫码延保半年
微信ID: mt-rip

选择这个是英文模式【如果是 6.0 的不需要选择，会自动选择语言】

Choosing this is the English mode【If you do not need to select 6.0, the language will be automatically selected】

安装 蒙泰彩色电子出版系统



选择安装路径

确定安装

Select the installation path

Determine the installation

安装 蒙泰彩色电子出版系统



扫码延保半年
微信ID:
mt-rip



安装MainTop

正在解压缩文件 adobe.dll.wpk

74%

按Esc键中止安装

等待安装完成

Waiting for installation to complete

安装 蒙泰彩色电子出版系统

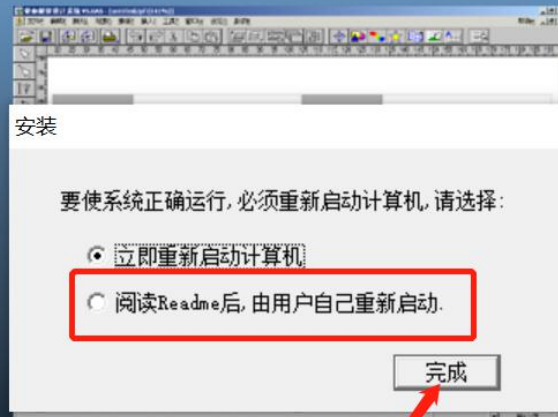

选择第二个再点击完成，可以避免电脑自动重启

Select the second one and then click Finish to prevent the computer from restarting automatically

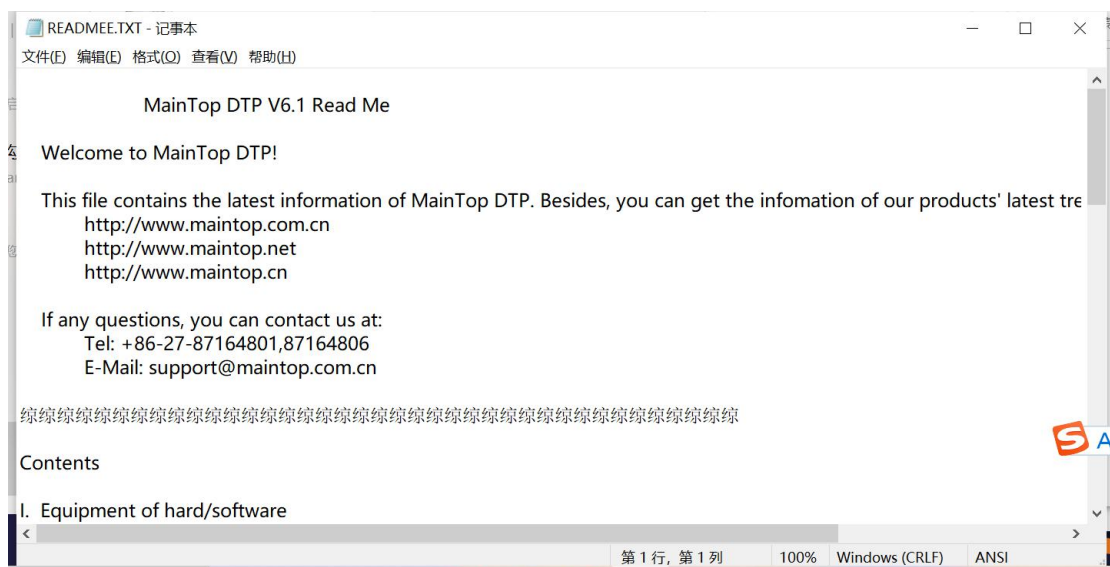

可以直接关闭它

You can just turn it off



找到桌面上的图标打开它

Go to the icon on the desktop and open it

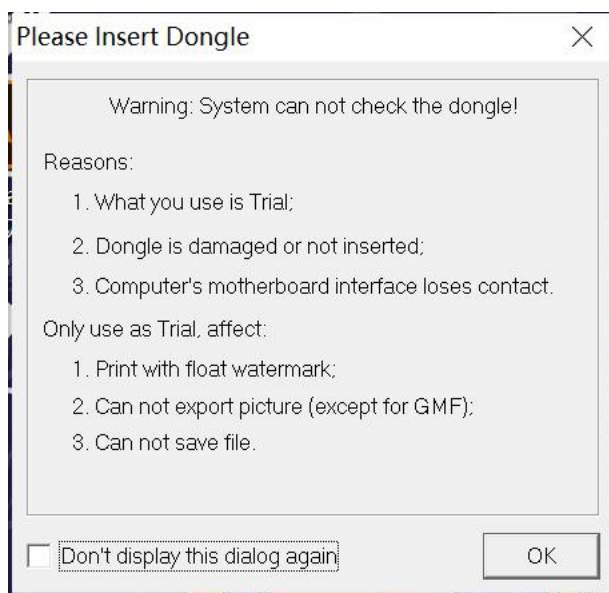

如果系统提示这个是因为你没有插入解密密匙

If the system is prompting this because you did not insert the decryption key



它在 maintop 的盒子里

It's in Maintop's box

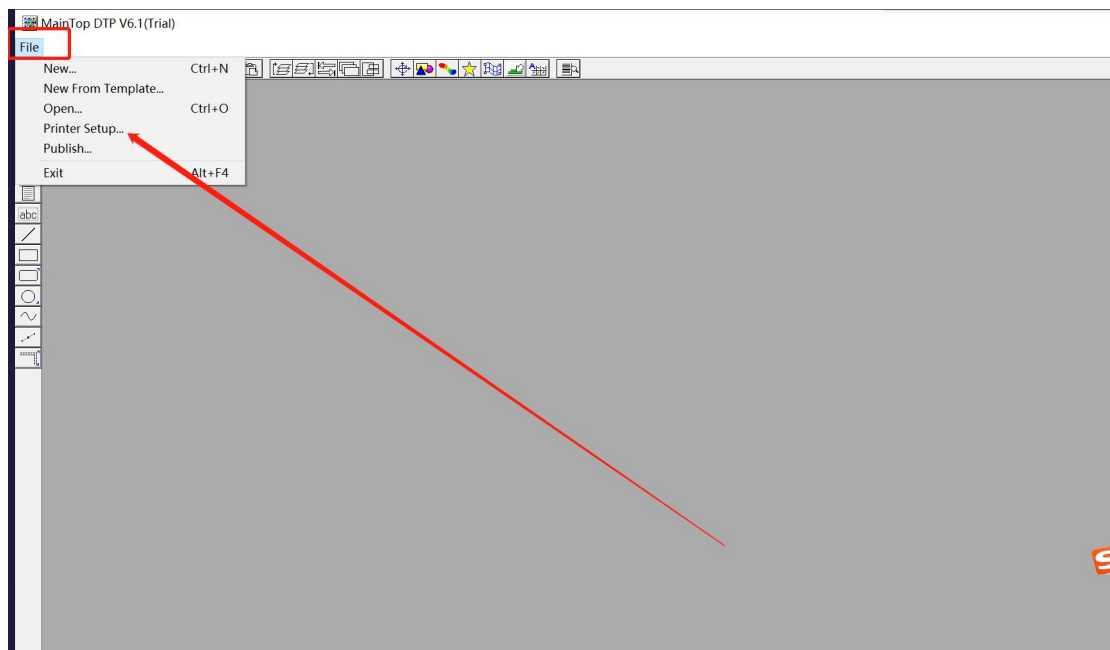

打开软件后在 File 里面选择安装打印机

Open the software and select Install the printer from File

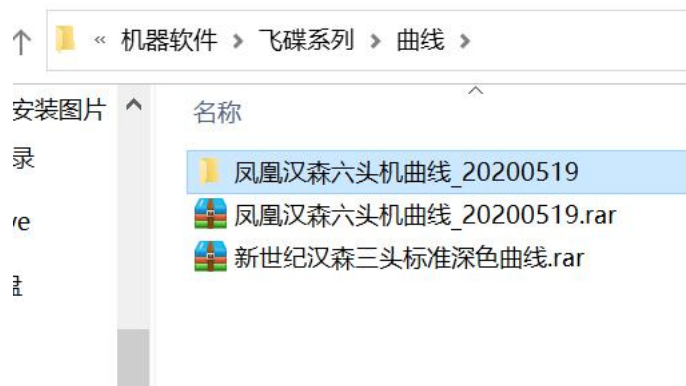

我们会给你发送打印机，解压后记住它的位置

We will send you the printer, unzip it and remember its location

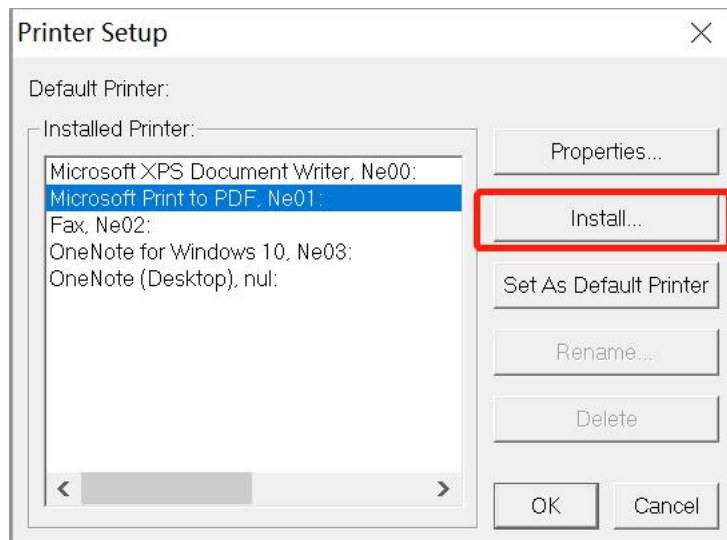

点击安装

Click on the install

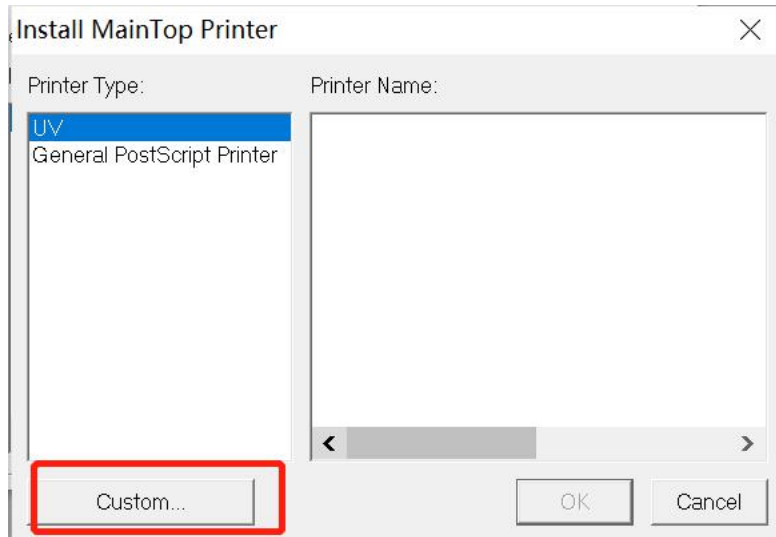

Click custom

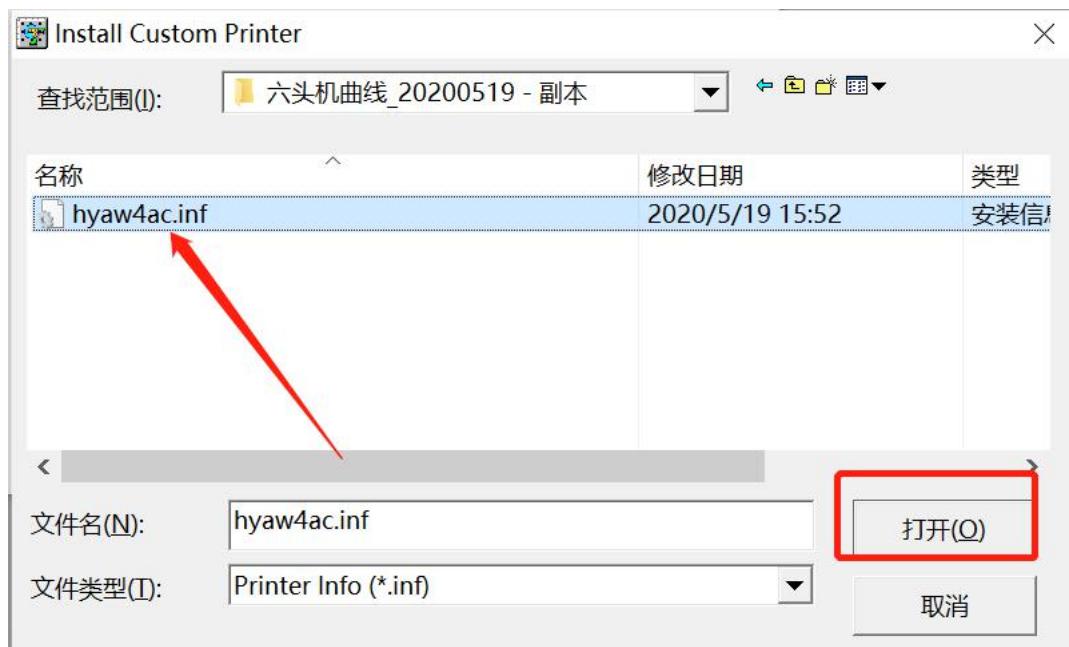

找到刚刚解压出来的文件打开

Find the file you just unzipped and open it

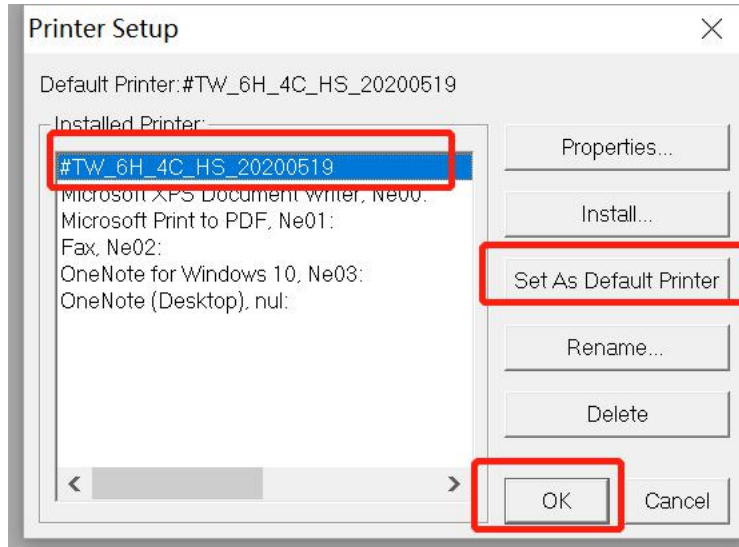

然后会回到这个界面，显示了刚刚安装的打印机，选中它，设置为默认打印机，点击 OK 就完成了我们的 maintop 安装

We will then return to this screen, showing the printer we just installed, select it, set it as the default printer, and click OK to complete our maintop installation

蒙泰排版教程

MainTop typesetting tutorial

1、打开蒙泰，点击左上角文件→建立新文件→确认建立新文件。

1. Open MainTop, click **File** in the upper left corner→**NEW**→ **OK**, Create a new file.

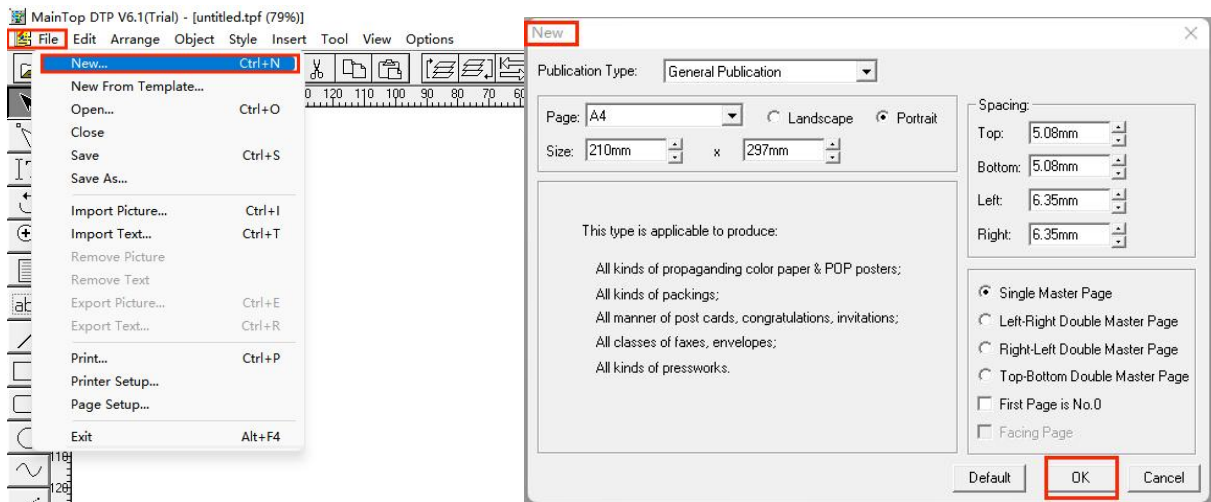

2、点击文件→载入图片，载入需要排版打印的图片。

2. Click **File** → **Import picture**, Load images that need to be typeset and printed.

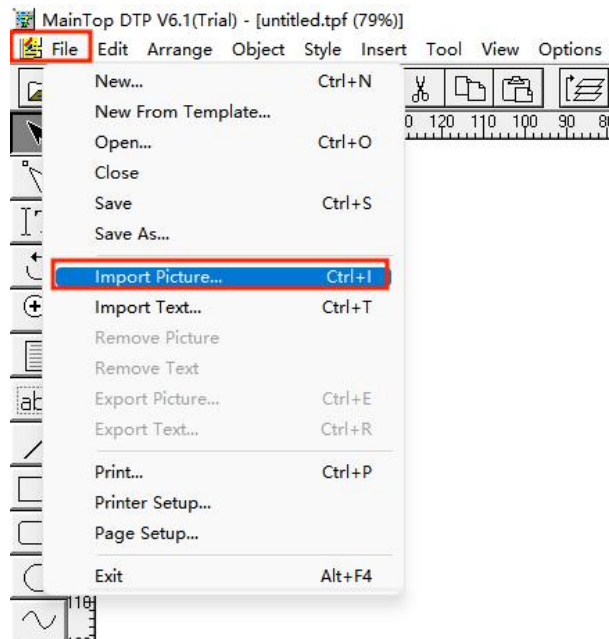

3、点击**定位显示面板**，再点击图片，可以显示图片的宽和高。

3.Click the **Show Metric Panel**, and then click the image to display the width and height of the image.

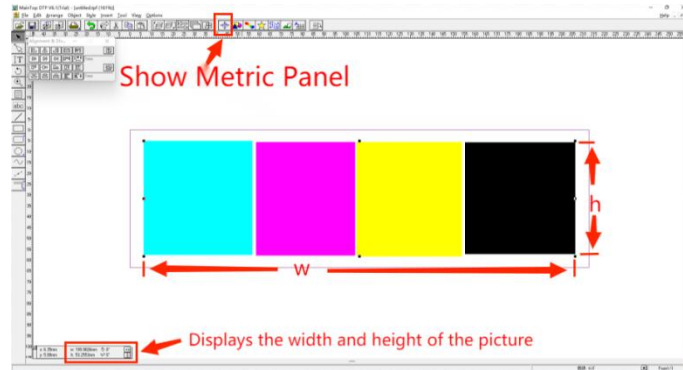

4、点击图片，然后右击，点击**图片框属性**可以修改图片大小。修改图片宽度后，再点击**保持图片纵横比**，图片高度会按照比例自动修改。

4.Click the image, then right-click, and click the **Frame Attribution** to modify the image size. After modifying the width of the image, click to **Constrain Proportion**, and the height of the image will be automatically modified according to the proportion.

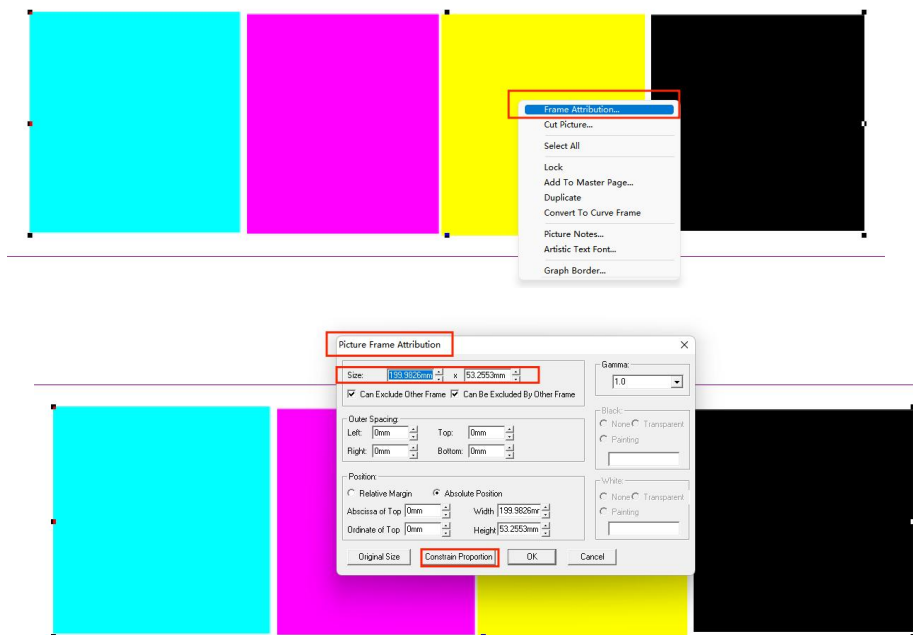

5、点击图片，然后按 **Ctrl + D** 可以复制图片，按一次复制一份图片。

5.Click on the picture and press **Ctrl+D** to copy the picture, press to copy one picture at a time.

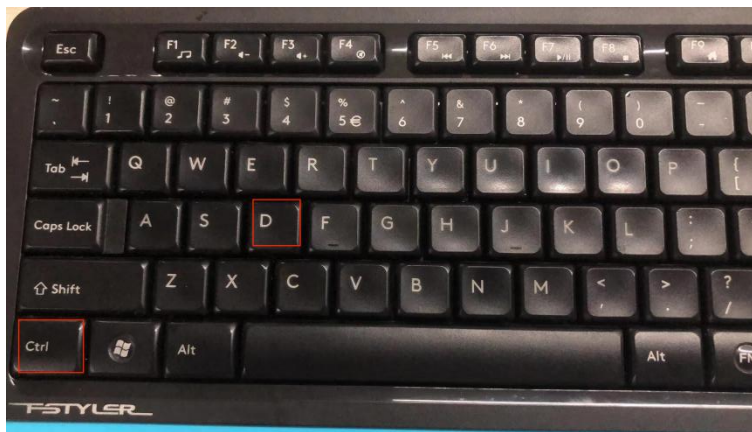
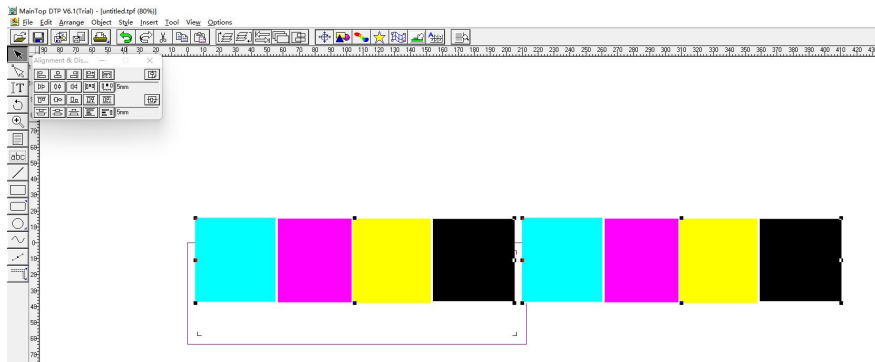

6、点击**显示靠齐与分布面板**，弹出靠齐与分布小弹窗设置图片的对齐方式。

6.Click **Show Alignment & Distributing Panel**, Pop-up snap and distribute small pop-ups to set the alignment of the image.

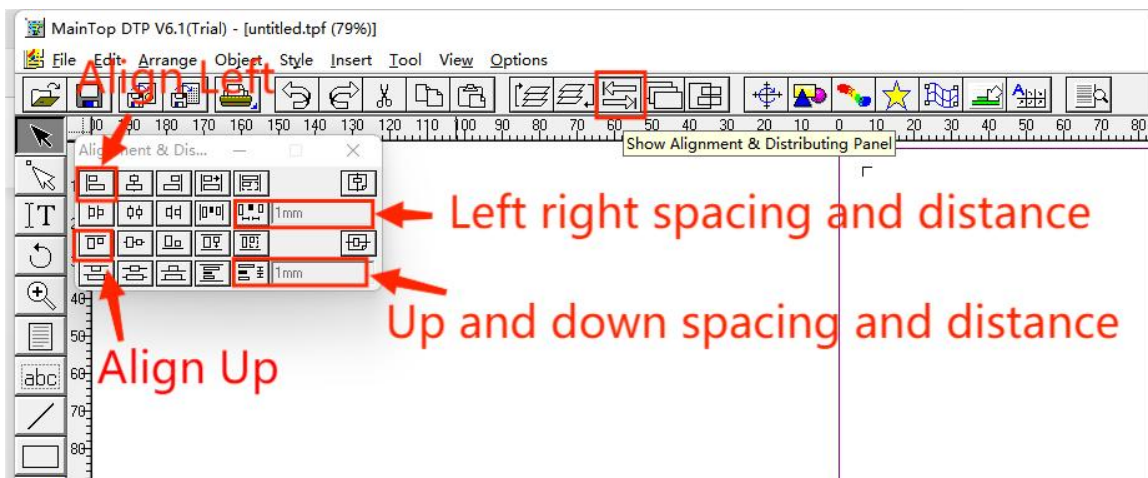

7、全选图片，点击 1 处，所有图片向上对齐。点击 2 处，修改图片横向间距，再点击 3 处，图片按设置的间隔排列。如图，现在图片与图片之间的左右间距是 5mm。

7.Select all images, click 1, all images are aligned up. Click 2 places to modify the horizontal spacing of the images, and then click 3 places to arrange the pictures according to the set interval. As shown in the figure, now the left and right spacing between the pictures is 5mm.

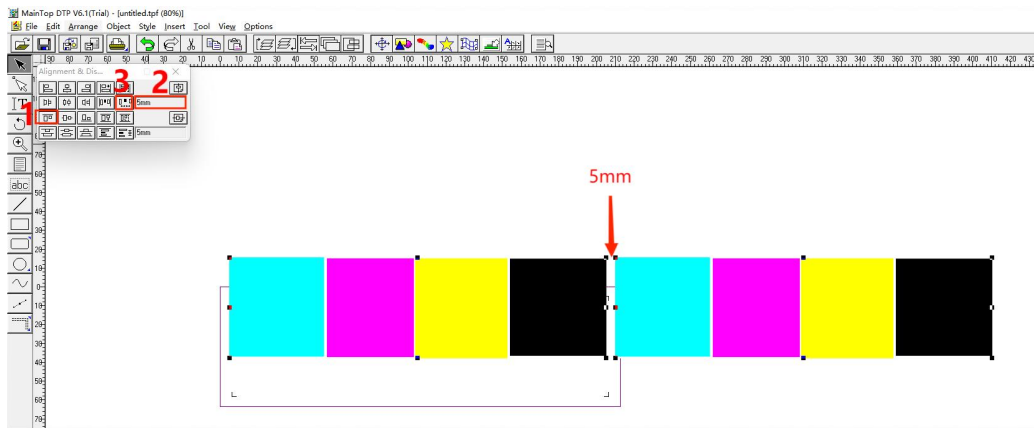

8、全选图片，然后点击 1 处，图片向左对齐。点击 2 处，修改图片纵向间距，再点击 3 处，图片按设置的间隔排列。如图，现在图片与图片之间的上下间距是 5mm。

8.Select all images and click 1 to align the image to the left. Click 2 places to modify the vertical spacing of the images, and then click 3 places to arrange the images in the set interval. As shown in the figure, now the upper and lower spacing between the pictures is 5mm.

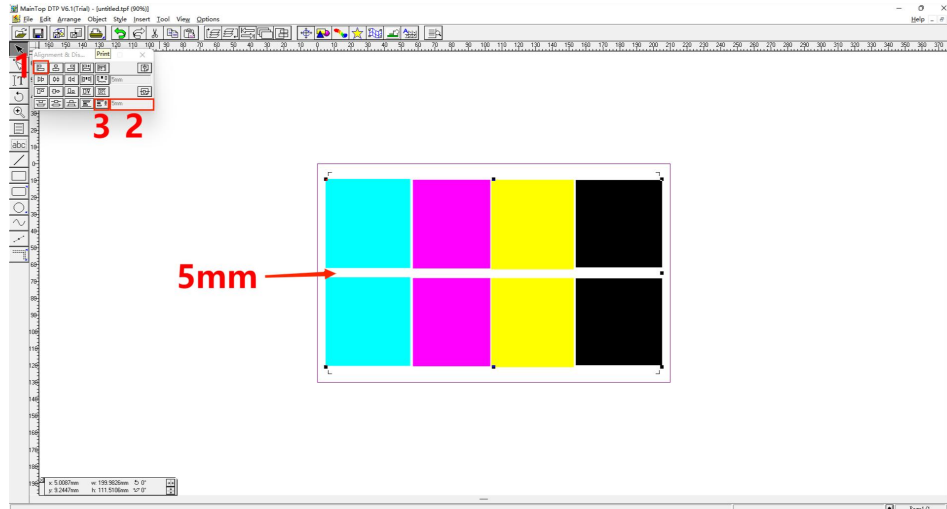

9、全选图片，然后右击，再点击**成组**，就可以把所有图片组成一个组合。

9.Select all images, then right-click, and click **Group** to group all the images into a group.

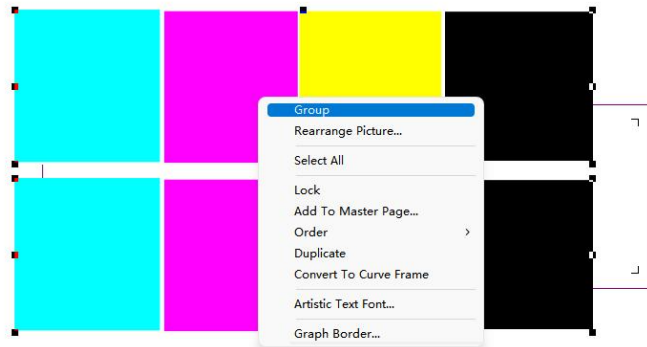

10、成组之后如果想解散图片组合，点击图片，再右击，点击**解组**，就可以解散图片组合。

10.After grouping, if you want to dissolve the picture group, click the image, then right-click, click **Ungroup**, you can dissolve the picture group.

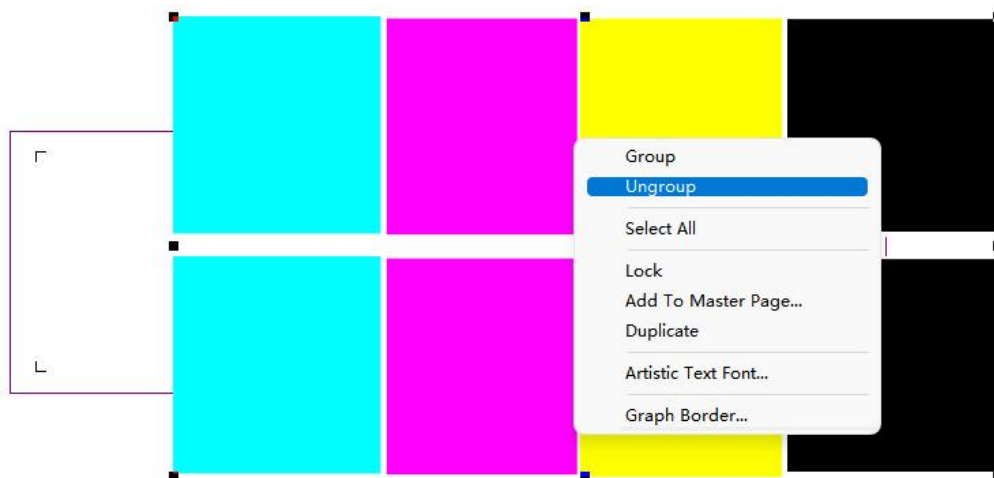

11、点击图片，然后文件→纸张设定可以设置纸张大小，纸张大小不能小于图片大小，可以根据定位面板的图片大小，设置纸张大小。现在图片大小是199.9826mm*111.5106mm，纸张大小就可以设置为200mm*112mm。

11. Click the picture, and then the file → paper settings can set the paper size, the paper size cannot be smaller than the picture size, and the paper size can be set according to the picture size of the positioning panel. Now the picture size is 199.9826mm*111.5106mm, and the paper size can be set to 200mm*112mm.

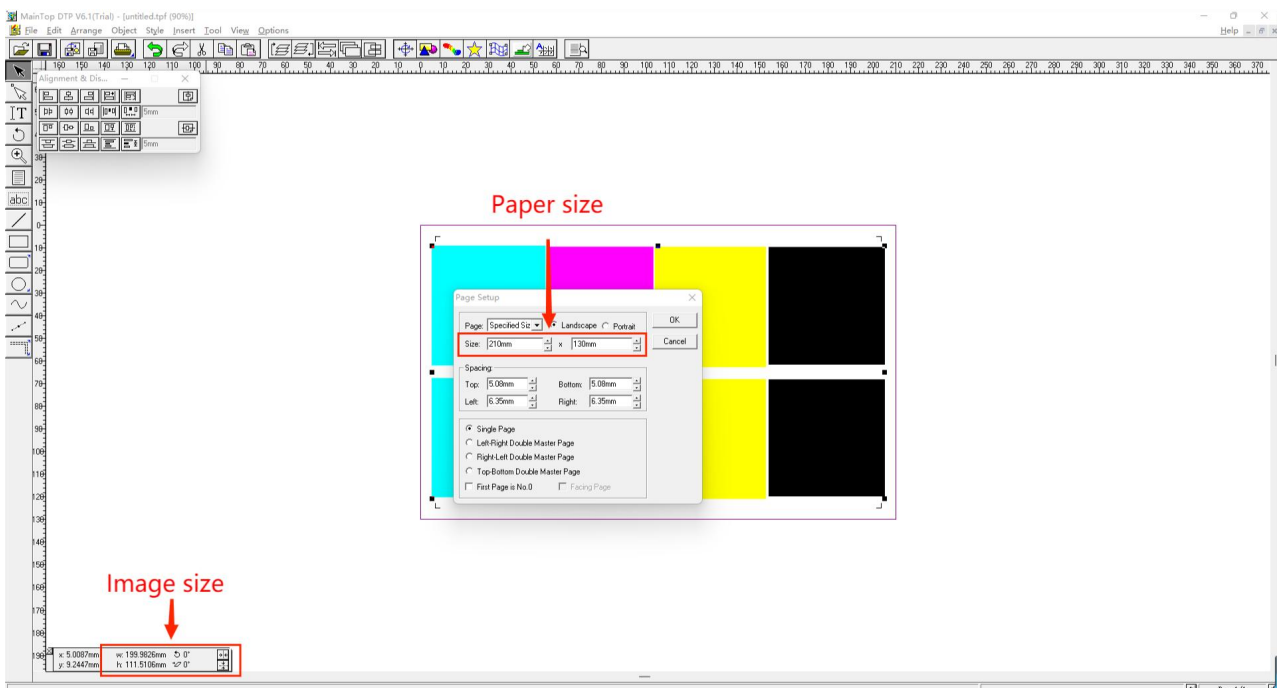
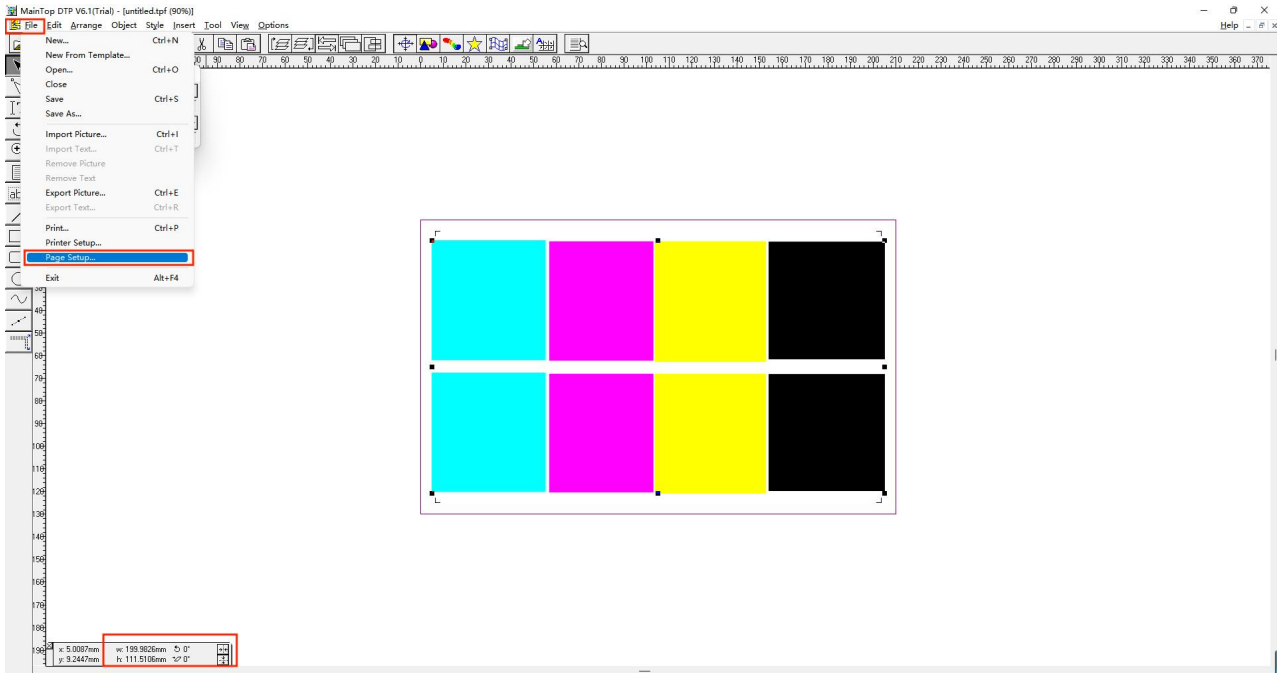

12、图片居中纸张。点击图片，点击1，上下居中。点击2，左右居中。

12. The picture centers the paper. Click on the image, click 1, and center it up and down. Click 2 to center left and right.

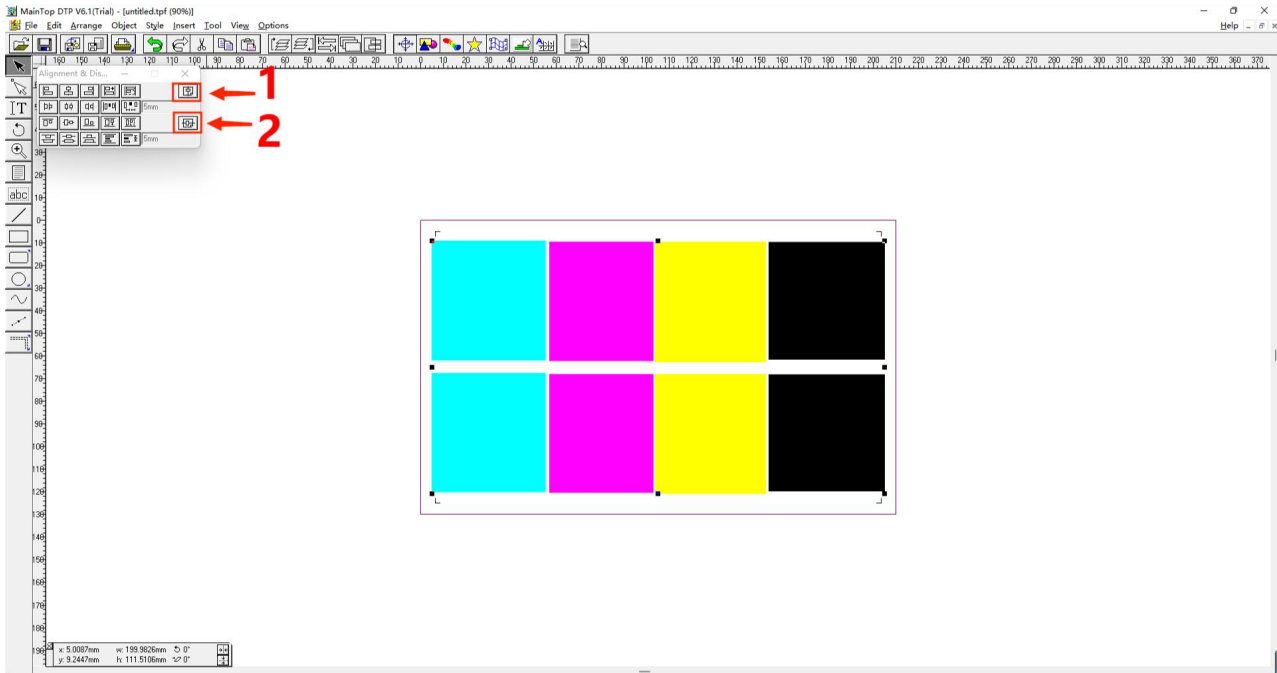

13、图片排版好后点击**打印图标**，进入打印设置。

13.After the image is typeset, click the **print icon** to enter the print settings.

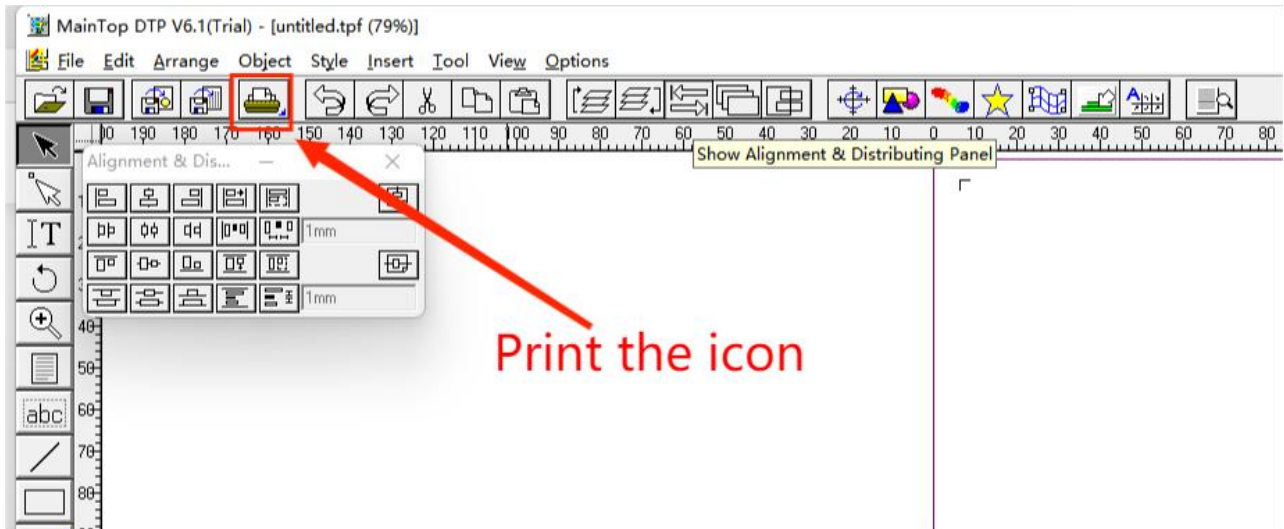

14、进入打印设置后，点击**打印机设定**→**自动设置纸张**→**确认**→**打印到文件**。

14.Once in the print settings, click **Printer Settings** → **Set Paper Automatically** → **OK** → **print to file**.

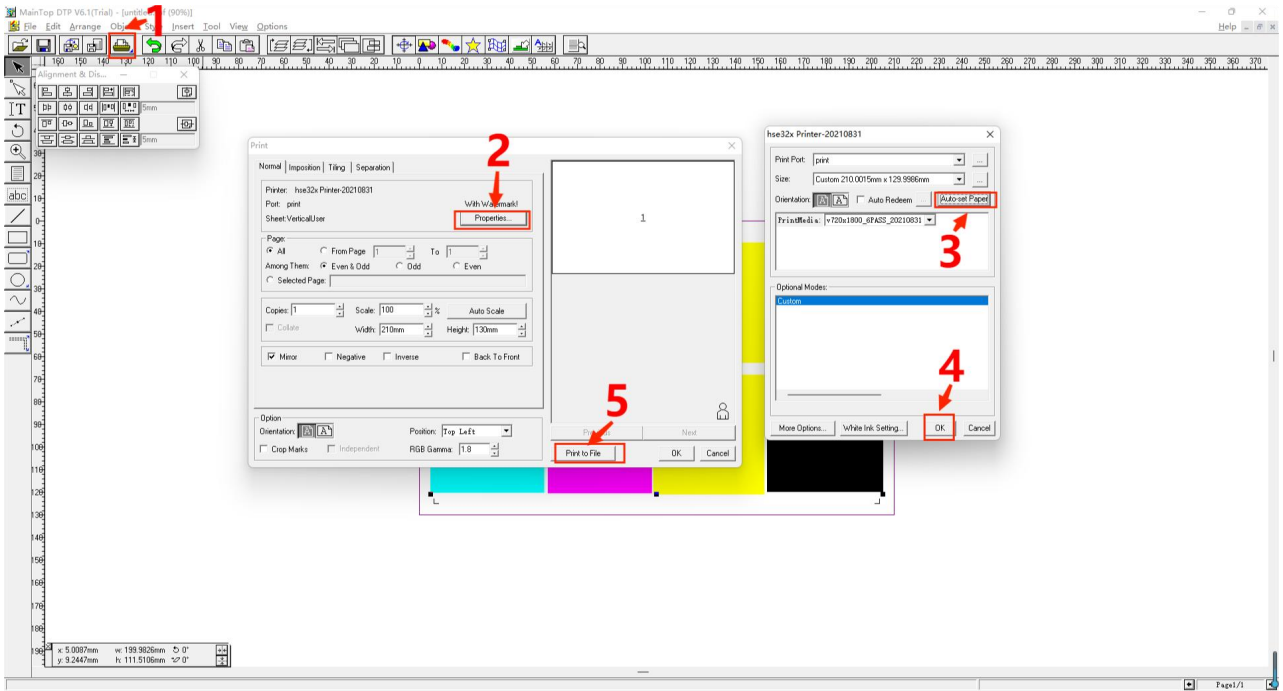

15、点击打印到文件后，选择保存路径，自定义文件名，再点击保存。

15.After clicking Print to file, select a save path, customize the file name, and then click Save.

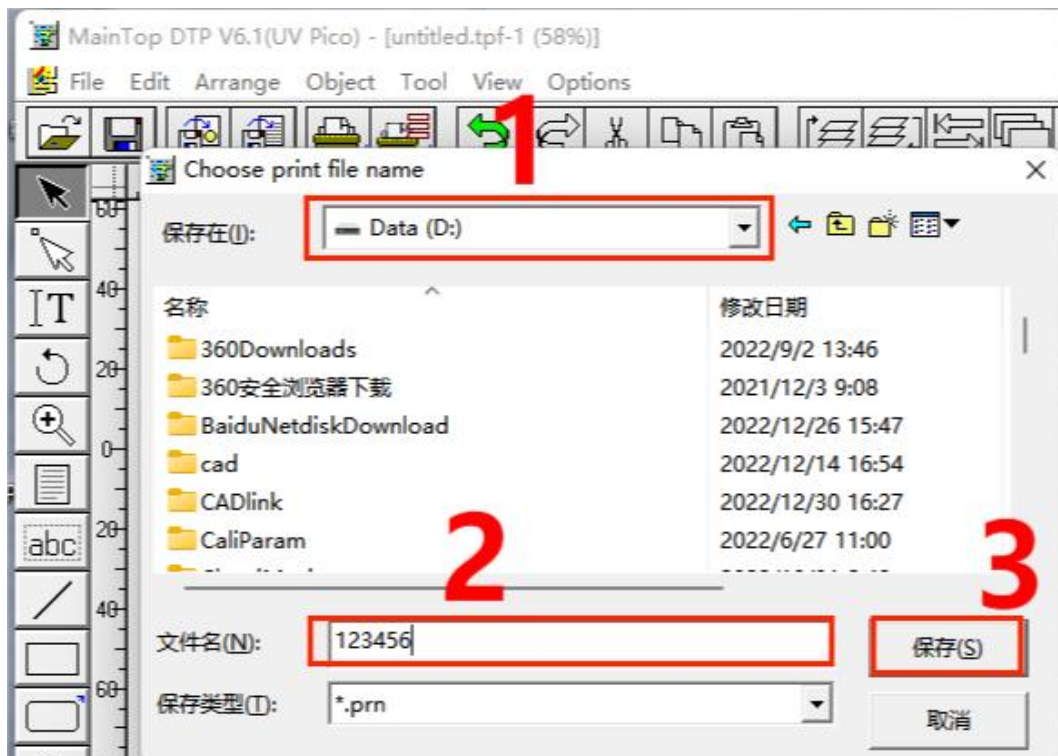

16、打开打印软件，点击文件，找到蒙泰排版完成的图片，右击添加倒打印列表。

16.Open the printing software, click File, find the finished picture of MainTop typesetting, right-click to add the reverse print list.

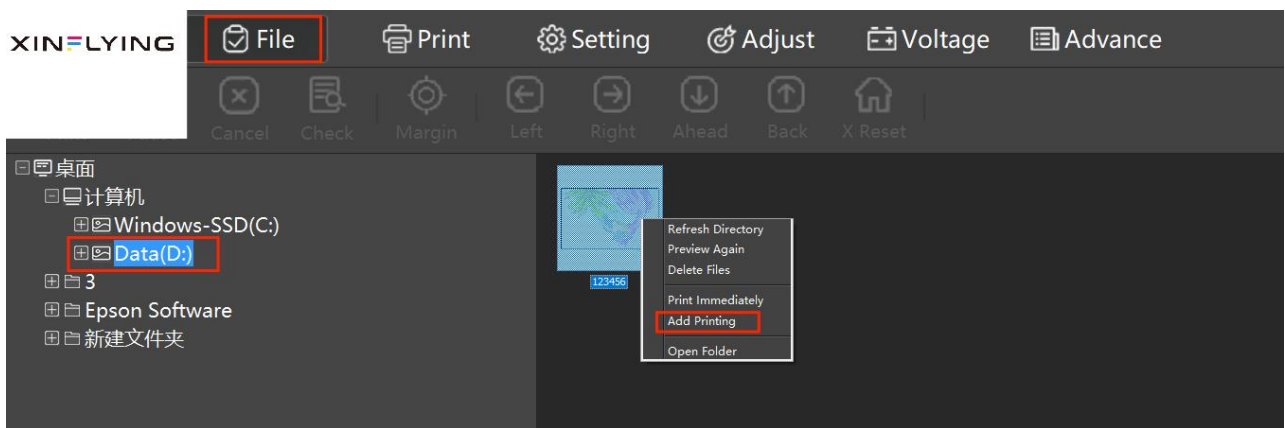

17、点击打印后，在打印任务列表中，右击打印任务，点击任务设置，进入任务设置。

17.After clicking Print, in the print task list, right-click the print task and click Task Settings to enter the task settings.

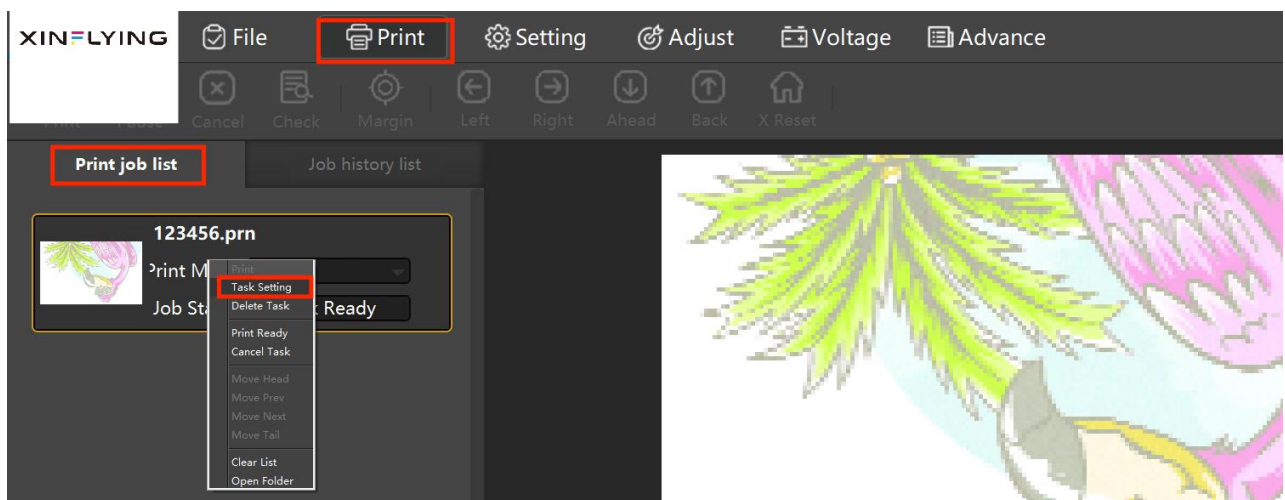

18、进入任务设置后，勾选连晒打印，编辑纵向幅数的数字，可以设置打印份

数，编辑**纵向间距**的数字，可以设置每份图片的纵向间距，设置完成后点击 ok。

如图，**纵向幅数**设置为 2，**纵向间距**设置为 1mm。

18.Once in the task settings, selected **Copy**, edit the number for **Y count**, you can set the number of copies, edit the number of **Y count**, you can set the vertical spacing of each picture, and click OK after setting. As shown in the figure, **Y count** is set to 2, and **Y count** is set to 1mm.

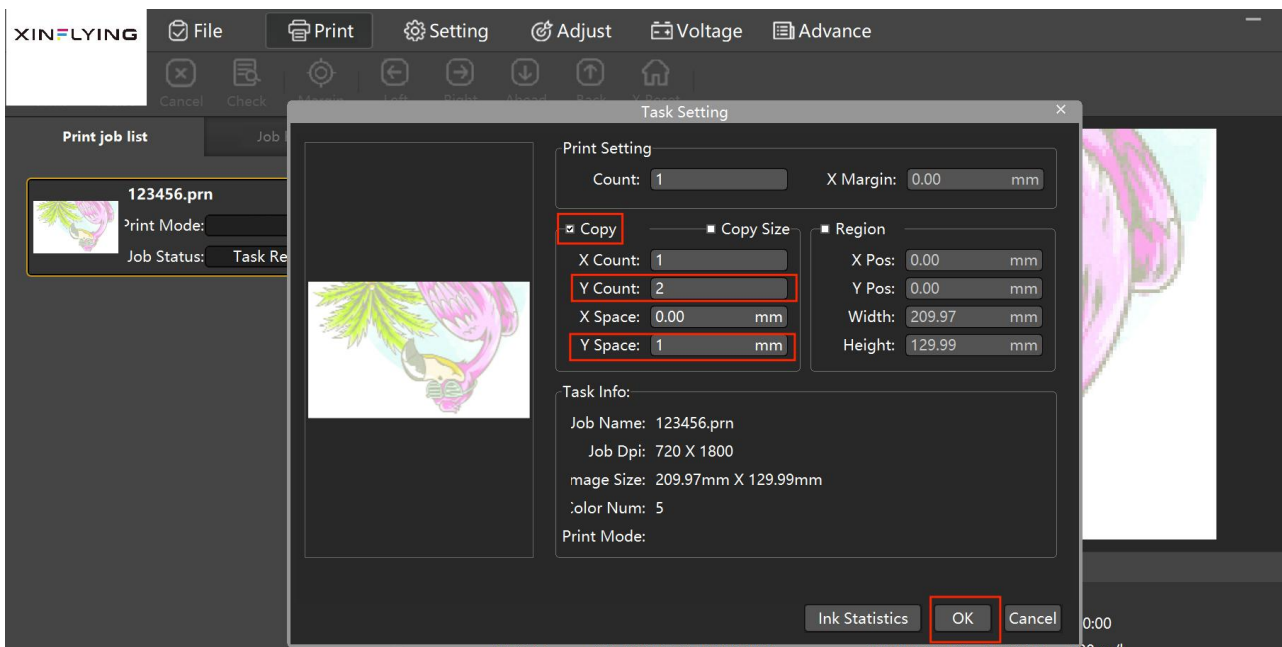

添加新的曲线

1、首先点击**文件**，再点击**打印机设定**。

First click file, then click printer settings.

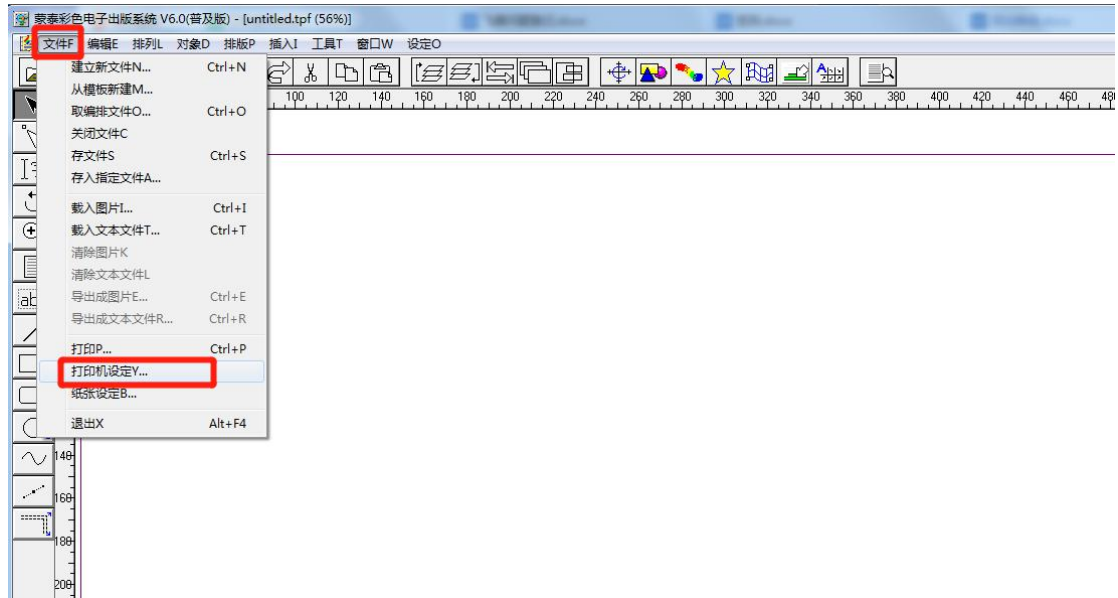

2、点击 1 处，**安装蒙泰打印机**。再点击 2 处，**自定义打印机**。

Click 1 to install the Montai printer. Then click 2 Custom printer

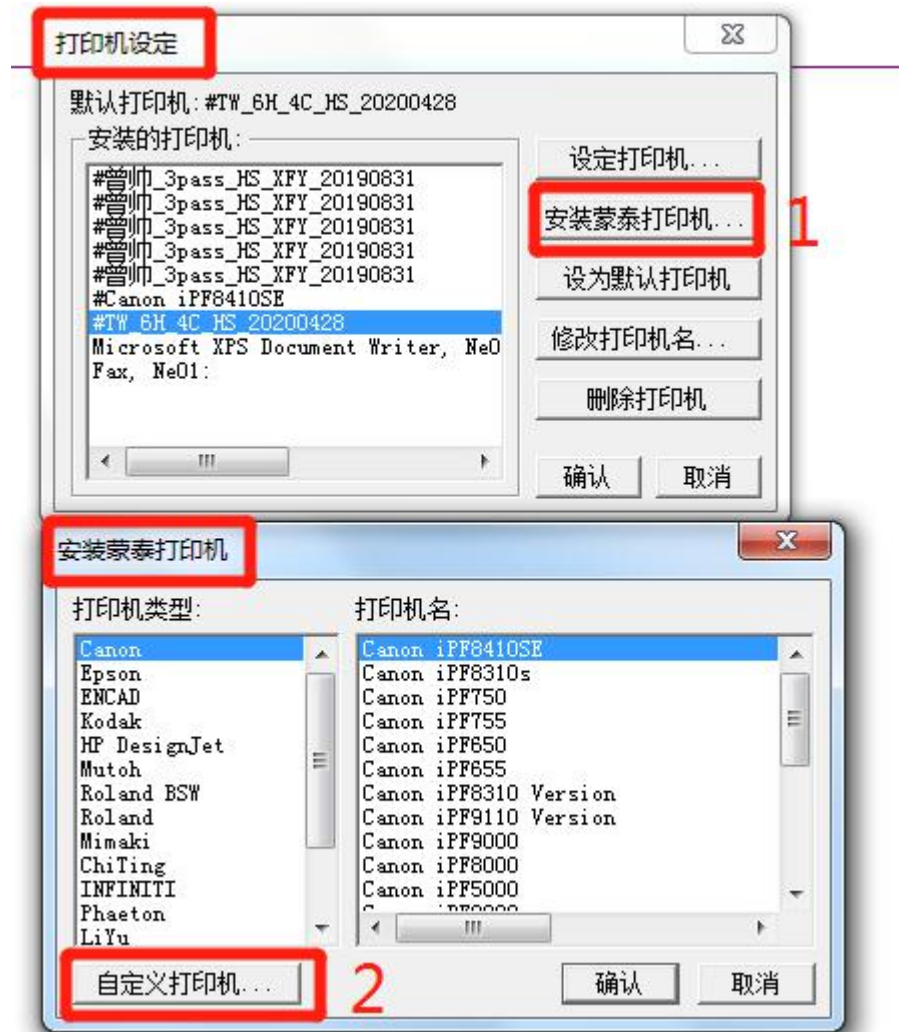

3、然后点击 3 处，找到需要安装的曲线，在点击打开。

Then click 3, find the curve to be installed, and click open.

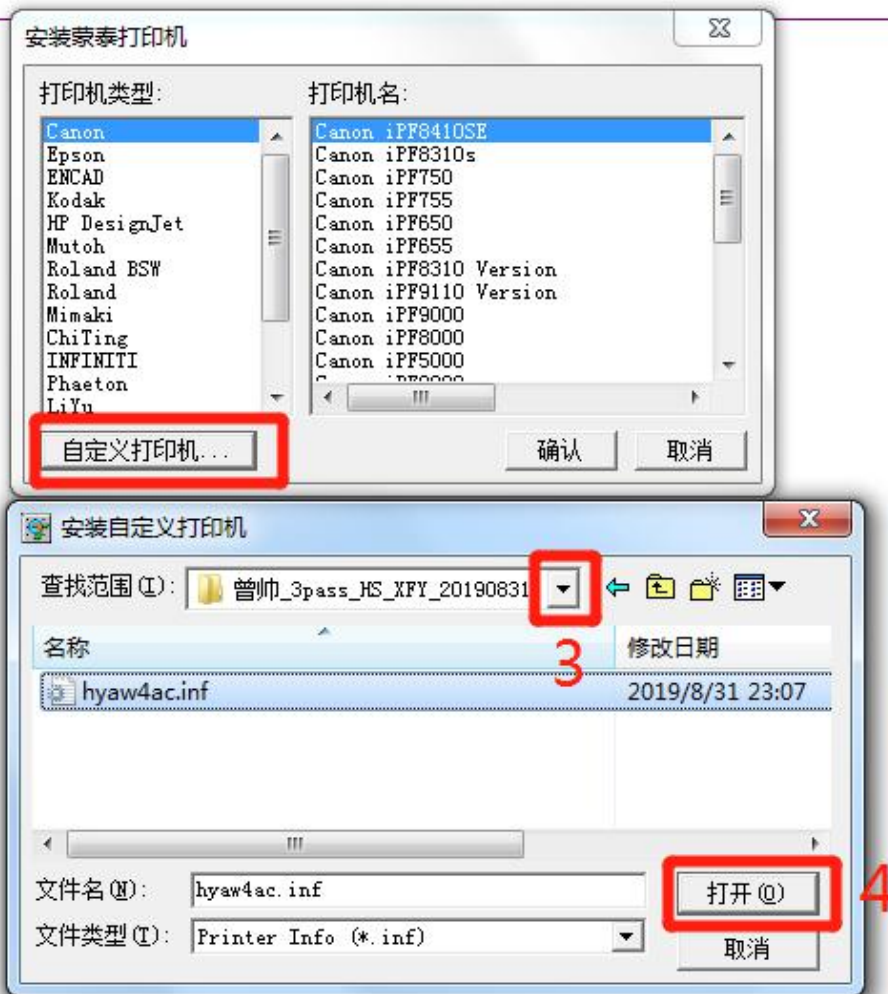

4、把刚刚安装的曲线设置为默认，点击**设为默认打印机**，再点击**确认**即可。

Set the curve you just installed as default, click set as default printer, and then click OK.

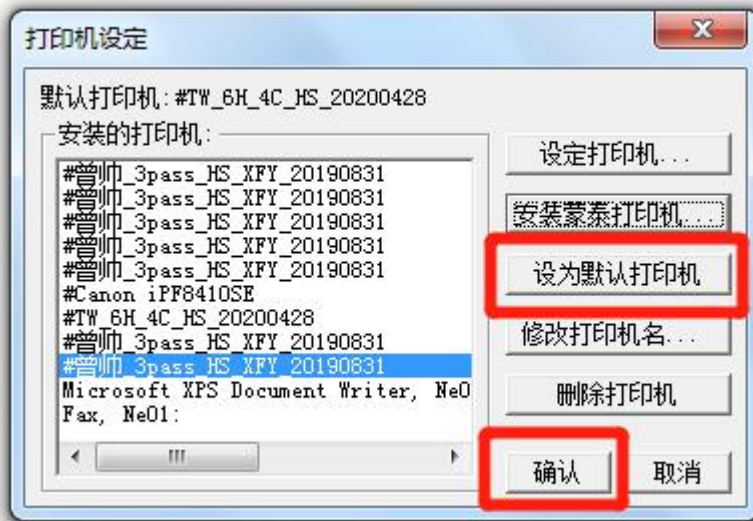

5、如果 icc 文件夹里面有 **mcm** 文件，需要把 icc 文件夹里面的 **mcm** 文件复制到 maintop 文件夹的 **DTP** 文件夹里面。如果没有，就不需要复制。

If there are MCM files in the ICC folder, you need to copy the MCM files in the ICC folder to the DTP folder in the Maintop folder. If not, there is no need to copy.

名称	修改日期
6p.icm	2021/3/15 21:17
6p_icc.cma	2021/3/15 21:17
111.cma	2021/3/15 20:14
hx5113.inf	2017/11/29 13:32
hx5113.mcm	2021/3/15 21:32
hx5113.prs	2021/3/15 21:34
hx5113c.wpk	2021/3/15 21:32
hx5113origin.wpk	2019/11/27 17:10
mtf7.pdv	2019/9/4 9:14
prevMtf.dat	2017/11/29 13:32

« 蒙泰个性UV » maintopUV-g » INSTALL » **maintop » DTP** 在 DTP 中搜索

名称	修改日期	类型
hpldr1gl.dll	2014/4/9 13:41	应用程序扩展
hpldr1gl.lib	2014/4/9 13:41	LIB 文件
html.epd	2007/5/30 15:27	EPD 文件
html.ipd	2007/5/30 15:23	IPD 文件
hx5113.mcm	2021/3/15 21:32	MCM 文件
hx51130.prs	2021/10/29 18:56	PRS 文件
hx51133.prs	2021/12/3 16:33	PRS 文件
hyaw4ac.prs	2022/3/21 9:58	PRS 文件
hyaw4ac0.prs	2022/4/25 19:15	PRS 文件
hyaw4ac1.prs	2022/4/27 1:09	PRS 文件
IME.INI	1997/4/30 3:30	配置设置